

FLAIL MOWER SFM – SERIES

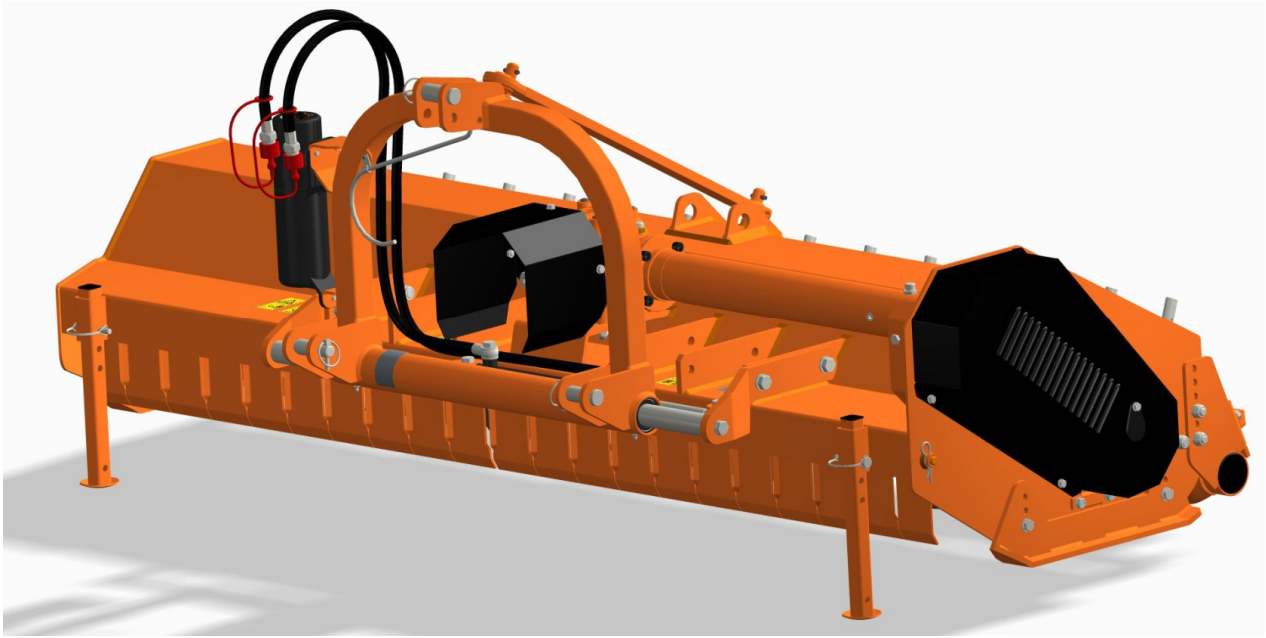

OPERATOR'S AND PARTS MANUAL



Tirth Agro Technology Pvt. Ltd.
“SHAKTIMAN”, Survey No.-108/1,
Plot No. B, NH-27, Nr. Bharudi Toll Plaza,
Bhunava (Village), Taluka: Gondal,
Dist.: Rajkot – 360311,
State: Gujarat- INDIA,
Phone: + 91 (2827) 661637 / 270537
Fax: + 91 (2827) 270457
e-mail: info@shaktimanagro.com
www.shaktimanagro.com

Manual P/N: OM2211-21EN-002_17

Congratulation for purchasing your new Sundown flail mower!

This machine has been designed and manufactured following all safety and quality requirements needed for a safe and satisfactory use over time.

A careful reading of this manual will permit you to familiarize with your new equipment, and will provide you all the tools needed to use it safely.

A proper maintenance and knowledge of the safety rules of use will allow to obtain the best performance and a long service life of the machine.



The Safety Alert Symbol used throughout this manual and on safety decals of the machine indicates the presence of potential hazard to the operator. When you see this symbol, be alert and carefully read the message that follows it.

The Safety Alert Symbol is used in conjunction with following Signal Words, according to the degree of possible injuries that may result operating the implement:



DANGER

Indicates an imminently hazardous situation that, if not avoided, will result in death or serious injury.



WARNING

Indicates a potentially hazardous situation that, if not avoided, could result in death or serious injury, and includes hazards that are exposed when guards are removed. It may also be used to alert against unsafe practices.



CAUTION

Indicates a potentially hazardous situation that, if not avoided, may result in minor or moderate injury. It may also be used to alert against unsafe practices.

IMPORTANT

Indicates instructions or procedures that, if not observed, can cause damage to equipment or environment.

NOTE

Indicates helpful information.

READ, UNDERSTAND, and FOLLOW the safety messages following the Safety Alert Symbol and Signal Words. Failure to comply with safety messages could result in serious bodily injury or death.

TO THE PURCHASER

This manual contains valuable information about SUNDOWN FLAIL MOWER. It has been carefully prepared to give you helpful suggestions for operating, adjusting, servicing repair parts.

Keep this manual in a convenient place for quick and easy reference. Study it carefully. You have purchased a dependable and sturdy Flail mower, but only by proper care and operation can you expect to get the service and long life designed and built into it.

RIGHT-HAND AND LEFT-HAND sides are determined by watching from the tractor side.

Sometime in the future your Flail mower may need new parts to replace those are worn or broken. If so, go to nearest SUNDOWN dealer and provide him the model and part number.

Customer information

Name _____

Purchased from _____

Purchased date _____

Model No. _____

Serial No. _____

TABLE OF CONTENTS

1. ABOUT THIS MANUAL	6
2. INTRODUCTION	6
2.1. MACHINE IDENTIFICATION	6
2.2. INTENDED USE	7
2.3. MAIN PARTS DESCRIPTION	8
2.4. CONFIGURATION	9
2.5. TECHNICAL SPECIFICATION	10
3. SAFETY	11
3.1. GENERAL SAFETY INSTRUCTIONS	11
3.2. EQUIPMENT SAFETY INSTRUCTIONS	12
3.3. OPERATING SAFETY INSTRUCTIONS	13
3.4. TRANSPORTING SAFETY INSTRUCTIONS	14
3.5. MAINTENANCE SAFETY INSTRUCTIONS	15
3.6. STORAGE SAFETY INSTRUCTIONS	16
3.7. SAFETY LABELS	16
4. SET UP	20
4.1. CONNECTING TO THE TRACTOR	20
4.2. DRIVELINE INSTALLATION	21
4.3. TRACTOR-FLAIL MOWER STABILITY	22
5. OPERATING	23
5.1. STRT-UP	23
5.2. OPERATING INSTRUCTIONS	24
5.3. ADJUSTMENTS	26
5.4. STOPPING AND DISCONNECTION	33
5.5. TRASPORTATION	33
6. MAINTENANCE	34
6.1. ROTOR TOOLS REPLACEMENT	34
6.2. GEARBOX LUBRICATION	36
6.3. ROTOR BEARINGS LUBRICATION	37
6.4. ROLLER BEARINGS LUBRICATION	37
6.5. WHEELS BRACKETS LUBRICATIONS	38
6.6. 3-POINT HITCH LUBRICATION	38
6.7. DRIVE BELTS REPLACEMENT	39
6.8. DRIVESHAFT MAINTENANCE	39
7. STORAGE	39
8. SCRAPING	39
9. TROUBLESHOOTING	40
10. TORQUE VALUES TABLE	41
11. WARRANTY	41
12. SPARE PARTS	43

1. ABOUT THIS MANUAL

The operator must read the manual for a correct understanding of the hazards that may present when operating the flail mower, as well as for obtain optimum performance from the machine.

The manual is part of the machine, it must be kept in good condition and remain with the machine even in case of resale, until its demolition. In case of loss or damage, request a new copy to the Manufacturer or your Dealer.

The information, descriptions and illustrations in this manual describe the state of the product at the time of its publication, and may not reflect the product in the future.

The Manufacturer reserve the right to make design improvements or changes in specifications without incurring in any obligation to install them on units previously sold.

Text, illustrations and drawings of this manual cannot be disclosed or transmitted, in whole or in part, to third parties without the written permission of the Manufacturer. All rights are reserved.

2. INTRODUCTION

2.1. MACHINE IDENTIFICATION

Each flail mower is provided with a plate for unique identification (see position in picture below), showing the CE marking together with following information:

- Manufacturer name and address
- Type of machine ("TYPE")
- Model of machine ("MODEL")
- Serial number ("SERIAL No.")
- Construction year ("YEAR")
- Machine weight ("MASS")

It's recommended to note down all data shown on the plate.

Any request for assistance or information regarding the machine must be directed to the Manufacturer or Dealer always referring to the model and serial number as shown on the plate affixed to the machine.

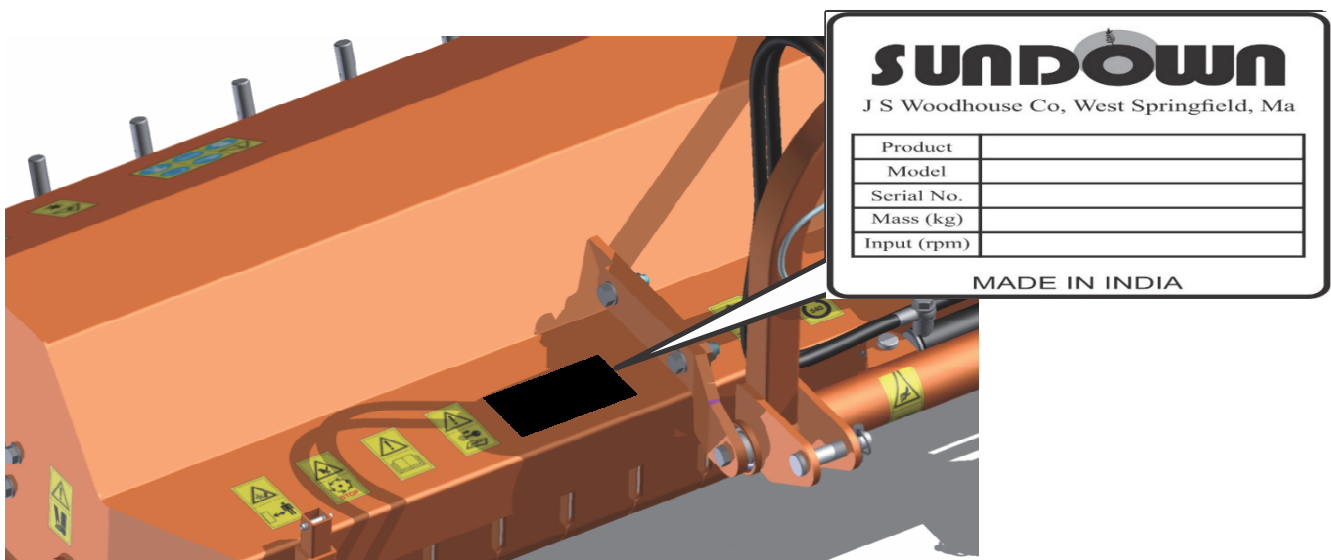

2.2. INTENDED USE

The SFM flail mower is designed specifically for cutting grass and for shredding fibrous and wood stalks, corn

and branches up to a diameter of 8 cm, depending on the type of tool used.

The flail mowers are designed to be mounted on tractors equipped with hydraulic lift and universal three point hitch that can support the implement weight, and driven by the power of the tractor through the PTO dri- veshaft.

The tractors used to operate the SFM flail mower must have the following requirements:

Hitch Category:	3-point hitch, I / II Category standard
PTO:	540 RPM, 6-spline, 1 3/8 Z6
Horsepower:	30-60 HP



DANGER

Any use of the machine other than the intended use is non-intended use, and is to be considered as unauthorized and dangerous. The manufacturer assumes no liability for damage resulting from non-intended use.

2.3. MAIN PARTS DESCRIPTION

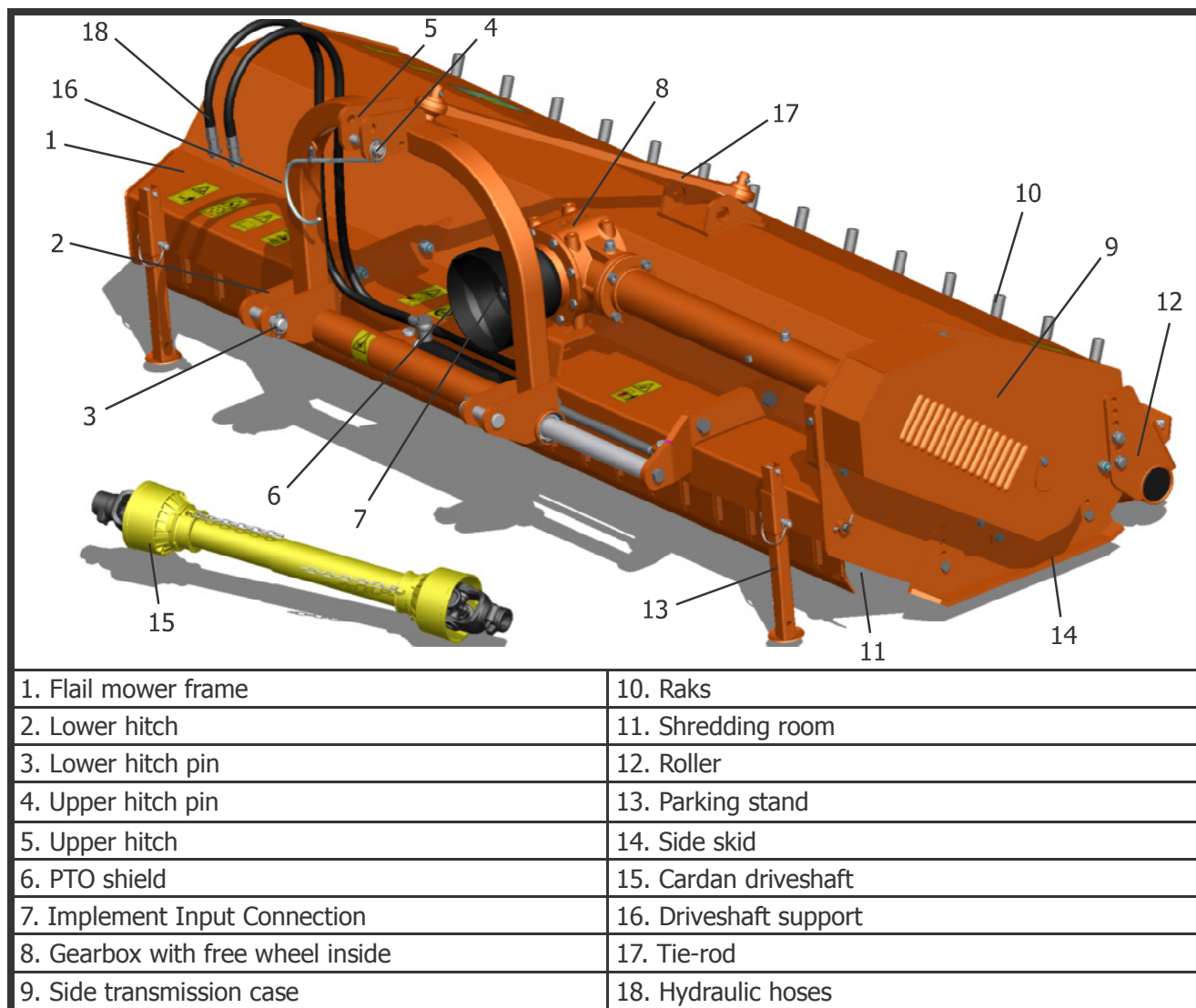



NOTE

To make the illustrations more clear, some images of this manual may refer to machines lacking of some components (e.g. safety devices and barriers).

2.4. CONFIGURATIONS

The SFM flail mower can be set in different configurations.

The standard configuration can be changed applying one or more optional parts, listed below:

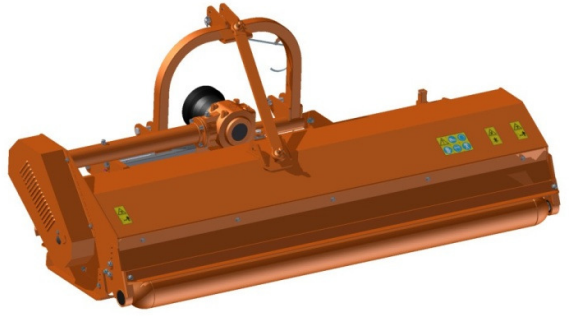
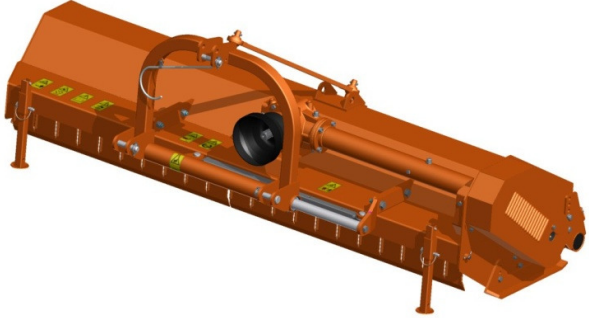
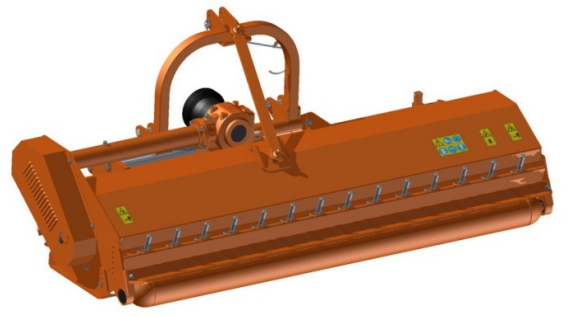
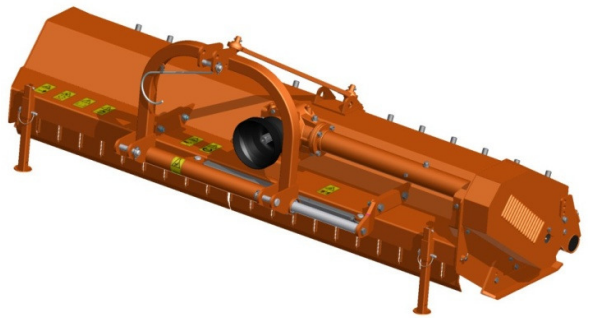
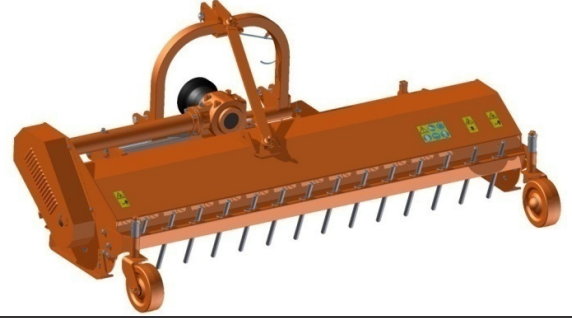
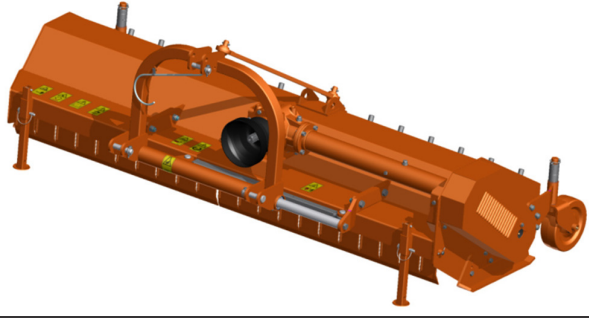
STANDARD CONFIGURATION	
	
<ul style="list-style-type: none"> • Mobile arc with hydraulic cylinder • Rear roller 	<ul style="list-style-type: none"> • Standard rear cover • "Y" blades or hammers
OPTIONAL	
	
<ul style="list-style-type: none"> • Mechanical shifting device (instead of hydraulic cylinder) 	
	
<ul style="list-style-type: none"> • Rear cover with raks (instead of standard rear cover) 	
	
<ul style="list-style-type: none"> • Rear floating wheels (instead of rear roller) 	

2.5. TECHNICAL SPECIFICATIONS

		Model								
		85	100	115	130	145	160	180	200	220
Overall dimensions	m m	1000x850x1130	1150x850x1130	1300x850x1130	1450x850x1130	1620x850x1130	1770x850x1130	1920x850x1130	2220x850x1130	2370x850x1130
Working width	m m	850	1000	1150	1300	1450	1600	1750	2050	2200
	inc hes	33	39	45	51	57"	63"	69"	80"	87"
Recommended tractor HP	HP / Kw	30-60 / 22-44	30-60 / 22-44	30-60 / 22-44	30-60 / 22-44	30-60 / 22-44	30-60 / 22-44	30-60 / 22-44	30-60 / 22-44	30-60 / 22-44
3-point hitch type	-	Cat. I/II	Cat. I/II	Cat. I/II	Cat. I/II	Cat. I/II	Cat. I/II	Cat. I/II	Cat. I/II	Cat. I/II
Number of blades	N.	20	24	28	32	36	40	44	52	56
Number of hammers	N.	10	12	14	16	18	20	22	26	28
PTO input speed	rp m	540	540	540	540	540	540	540	540	540
Rotor speed	rp m	2083	2083	2083	2083	2083	2083	2083	2083	2083
Side transmission	-	3 belts	3 belts	3 belts	3 belts	4 belts	4 belts	4 belts	4 belts	4 belts
		BX type	BX type	BX type	BX type	BX type	BX type	BX type	BX type	BX type
Side shift (max)	m m / Inc h	FIX MOUNTING	FIX MOUNTING	FIX MOUNTING	300 / 11.81	300 / 11.81	300 / 11.81	300 / 11.81	300 / 11.81	300 / 11.81
Rotor diameter	inc hes	6.25"	6.25"	6.25"	6.25"	6.25"	6.25"	6.25"	6.25"	6.25"
	m m	159	159	159	159	159	159	159	159	159
Rotor swing diameter	m m	378	378	378	378	378	378	378	378	378
Approx Weight (driveline not included)	kg	278	300	320	366	388	412	434	482	506

3. SAFETY

Proper use of the equipment, a strict observance of the safety messages listed below and application of all reasonable practices to avoid any risks, prevents accidents or injury, allows the machine working better and longer, and minimize the failures.

The manufacturer assumes no liability for any damage resulting from not applying the behavioral rules indicated into the manual.

3.1. GENERAL SAFETY INSTRUCTION



DANGER

The machine must be used only by authorized and well trained operators. The operator must have read and understood the instructions of this manual, it must make adequate preparation for the proper use of the machine and must hold a driving license. In case of doubt about the use of the machine and/or the interpretation of this manual, the operator must contact the Manufacturer or the Dealer.



WARNING

The manual must always remain with the machine. In case of loss or damage, request a new copy to the Manufacturer or your Dealer.



WARNING

Follow strictly the rules prescribed by the safety pictograms applied to the machine.



WARNING

Be sure that all safety pictograms are legible. If pictograms are worn, they must be replaced with others obtained from the Manufacturer, and placed in the position indicated by this manual.



DANGER

Before using the machine, make sure that all safety devices are installed and in good working conditions. In case of damages of shields, replace them immediately.



DANGER

Is absolutely forbidden to remove or alter safety devices.



DANGER

Before starting, and during operation of the flail mower, make sure there are no people or animals in the operation area: the machine can project material from the back, with risks of serious injury or death.



DANGER

Pay maximum attention to avoid any accidental contact with rotating parts of the machine.



DANGER

During operation, adjustment, maintenance, repairing or transportation of the machine, the operator must always use appropriate Personal Protective Equipment (PPE).

 **DANGER**

Do not operate the implement while wearing loose fitting clothing that can give rise to entanglement in parts of the machine.

 **DANGER**

Do not operate the implement when tired, not in good condition or under the influence of alcohol or drugs.

 **CAUTION**

If the use of the machine is required at night or in conditions of reduced visibility, use the lighting system of the tractor and possibly an auxiliary lighting system.

3.2. EQUIPMENT SAFETY INSTRUCTION

 **WARNING**

Use the flail mower for its intended purpose only. Improper use can damage the flail mower and cause serious injury to persons, animals, or death.

 **DANGER**

The machine should be used by a single operator driving the tractor.

 **WARNING**

Any unauthorized modification of the machine may cause problems in safety and relieves the Manufacturer from any liability for damages or injuries that may result to operators, third parties and objects.

 **WARNING**

Before using the machine, familiarize yourself with its controls and its working capacity.

 **WARNING**

Do not leave the flail mower unattended with tractor engine running.

 **WARNING**

Do not operate flail mower on too muddy, sandy or rocky soils.

 **WARNING**

Keep the machine clean from debris and foreign objects which may damage functioning or cause injury.

 **WARNING**

Do not use the machine if the category of the connecting pins of the flail mower does not match that of the tractor hitch system.

 **WARNING**

Do not use the machine with missing bolts, screws, pins or safety pins, safety guards etc.

**WARNING**

Never use the machine to transport or lift people, animals or objects.

**WARNING**

Make certain, by adding front ballast, that at least 20% of the total weight (tractor, implement and ballast) is on the front axle of the tractor, to ensure stability.

**WARNING**

Before engaging the tractor PTO, make sure the tractor PTO speed is set as required for the flail mower (540 rpm). Do not over speed PTO or machine breakage may result.

**DANGER**

Do not operate the flail mower if the driveshaft is damaged. The driveshaft could be subject to breakage during operation, causing serious injury or death. Remove the driveshaft and replace it with an undamaged.

**WARNING**

With flail mower disconnected from tractor, rest the driveline on the provided support of the flail mower.

3.3. OPERATING SAFETY INSTRUCTION

**WARNING**

Before using the machine, be sure to have cleared the operating area from obstacles (stones, branches, debris, etc...). Mark all the obstacles that cannot be eliminated (e.g. by means flags).

**DANGER**

Never engage the tractor PTO in the presence of people close to the driveshaft. The body, hair or clothing of a person can get caught in rotating parts, causing serious injury or death.

**DANGER**

Before engaging the PTO and during all operations, make sure that no person or animal is in immediate area of action of the machine. Never use the flail mower if people are in his working area.

**DANGER**

It's absolutely forbidden to stand near the flail mower with moving parts.

**WARNING**

The operator must operate machine lifting/lowering only from the driving seat of the tractor. Do not perform lifting maneuvers on side or behind the tractor.

**WARNING**

Before making changes in direction, turns or going in reverse, slightly lift the flail mower from the ground after disengaging the power take-off, to avoid damage to the machine.

 **DANGER**

In presence of steep slopes (greater than 15 degrees) the tilling action may cause instability of the tractor with risk of serious injury or death hazard. Consult the manual for the tractor to determine the maximum slope that the tractor is able to deal with.

 **DANGER**

Always disengage the PTO before raising the flail mower, and never engage the PTO with the flail mower in the raised position. The machine might throw objects at high speed, causing serious injury or death.

 **WARNING**

Never leave the driver's seat when the tractor is turned on. Before leaving the tractor, lower the flail mower to the ground, disengage the PTO, insert the parking brake, stop engine and remove the key from the control panel.

 **DANGER**

The PTO shields of tractor and implement side, the driveshaft shielding and the driveshaft retaining chains must be properly installed and in good condition, to avoid risk of entanglement with serious injury or death.

 **DANGER**

Before engaging the PTO of the tractor, always make sure that the driveshaft is mounted in the correct direction, and that its clamping elements are properly connected both to tractor side and to flail mower side.

 **WARNING**

Stop operating immediately if blades strike a foreign object. Repair all damage and make certain rotor and blades are in good condition before resuming operation.

 **WARNING**

Always disengage the tractor PTO when the driveshaft exceed an angle of 10 degrees up or down while operating. An excessive angle with driveshaft rotating can break the driveshaft and cause flying projectiles.

 **CAUTION**

Prolonged use of the flail mower can cause overheating of the gearbox. Do not touch the gearbox during use and immediately after, it could be extremely hot and cause severe burn.

 **WARNING**

All adjustment operations on the flail mower must be performed by qualified and trained operators, with the tractor engine off, the PTO disengaged, the flail mower lowered to the ground or on security stands, the ignition key off and the parking brake set.

3.4. TRANSPORTING SAFETY INSTRUCTION

 **WARNING**



WARNING

Transport only at speeds where you can maintain control of the equipment.



WARNING

When driving on roads, the implement must be in transport position adequately raised from the road surface, with tractor lifting hydraulics locked so that the flail mower cannot be lowered accidentally.



DANGER

The implement may be wider than the tractor. Pay attention during transporting to persons, animals or obstacles exposed.



WARNING

When turning, use extreme care and reduce tractor speed.



WARNING

Do not operate the tractor with weak or faulty brakes or worn tires.



CAUTION

Always use tractor lighting system and auxiliary lighting system for an adequate warning to operators of other vehicles, especially when transporting at night or in conditions of reduced visibility.



PERICOLO

In case is required the lifting of the machine, make sure that the lifting device chosen is suitable to perform the operation safely, and use only the lifting points prescribed on flail mower.

3.5. MAINTENANCE SAFETY INSTRUCTION



WARNING

All maintenance and repairing operations must be performed by qualified and trained operators, with the tractor engine off, the PTO disengaged, the flail mower lowered to the ground or on security stands, the ignition key off and the parking brake set.



WARNING

Perform repairs and replacements necessary to the machine using only original spare parts provided by the manufacturer or your Dealer.



DANGER

Perform maintenance operations always using appropriate Personal Protective Equipment (protective eye glasses, hard hat, hearing protection, safety shoes, overall and work gloves, filter mask).

 **CAUTION**

Before any maintenance operation, make sure that the parts which may become hot during use (gear box) have cooled.

 **WARNING**

Do not perform repairs that you do not know. Always follow the manual instructions and in case of doubt contact the Manufacturer or your Dealer.

 **DANGER**

Do not swallow fuels or lubricants. In case of accidental contact with eyes, rinse well with water and consult a doctor.

3.6. INFORMAZIONI RELATIVE ALL'IMMAGAZZINAMENTO

 **WARNING**

Never leave the tractor unattended with the flail mower in lifted position. Accidental operation of lifting lever or a hydraulic failure may cause sudden drop of unit with injury or death by crushing.

 **DANGER**

Following operation, or before unhooking the machine, stop the tractor, set the brakes, disengage the PTO, lower the flail mower to the ground, shut off the engine, remove the ignition key and wait for all moving parts to stop.

 **WARNING**

Make sure all parked machines are on a hard, level surface and engage all safety devices.

 **CAUTION**

Place support blocks under flail mower as needed to prevent unit from tipping over onto a child and/or an adult. A flail mower that tips over can result in injury or death.

 **CAUTION**

Store the unit in an area away from human activity.







3.7. SAFETY LABELS

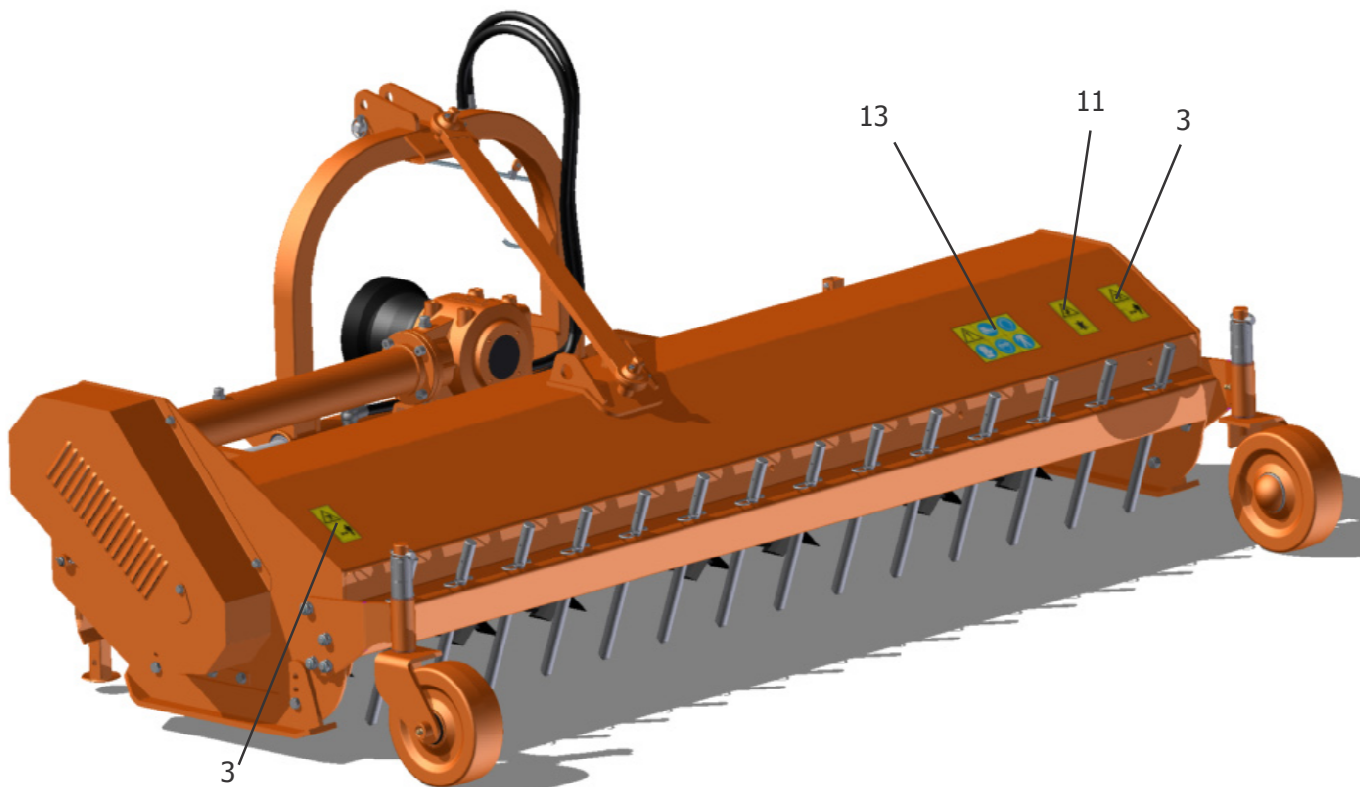
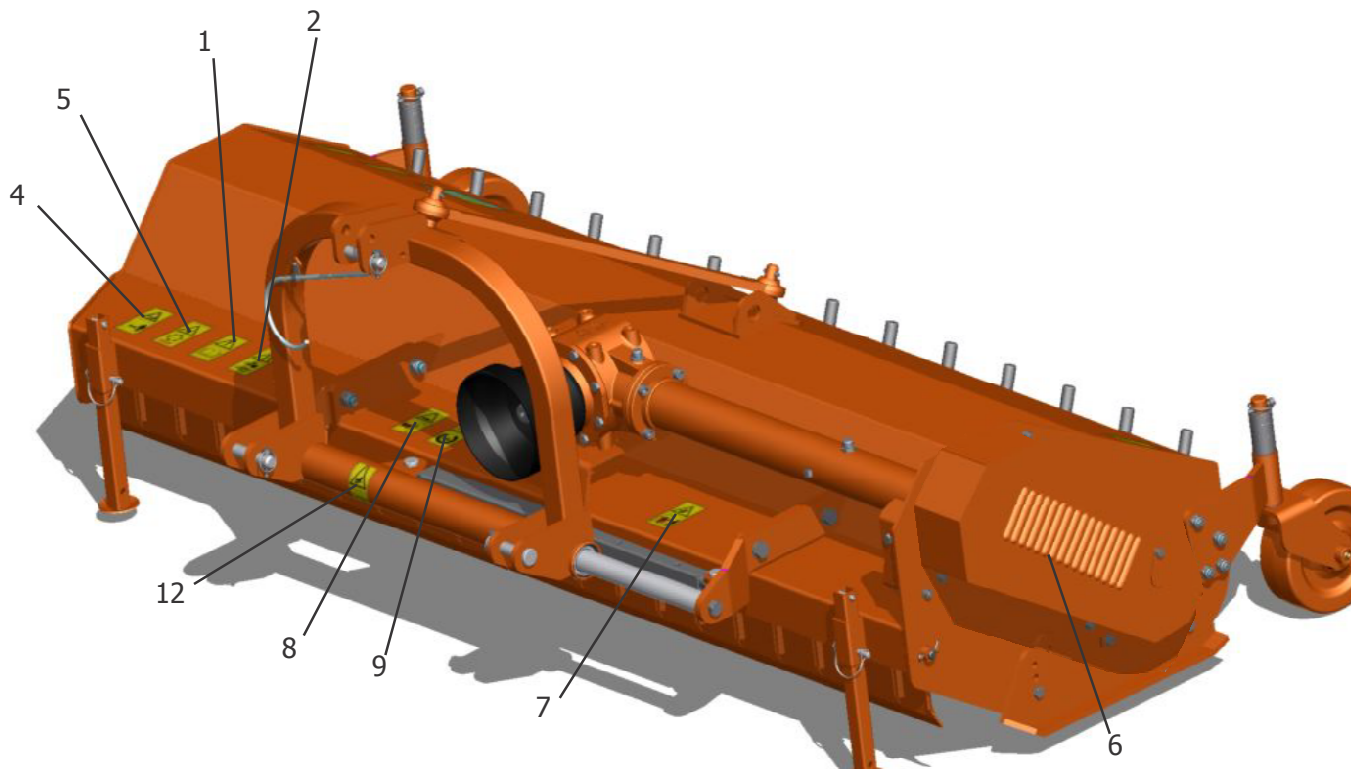





The safety labels on the machine provide key information for use in the safety of the machine. Make sure all the labels are in good condition. If the labels are deteriorated, they must be replaced as with others provided by the manufacturer,

and placed in the position shown in this manual. Make sure all the labels are readable. If necessary, clean them using a cloth with soap and water.

SAFETY LABELS POSITION AND DESCRIPTION



1		<p>Carefully read the operator's manuals of the flail mower, tractor and cardan shaft before using the machine</p>
2		<p>Disengage the PTO, turn off the tractor engine, remove the key and ensure that all rotating parts have stopped before approaching the implement. Read the operator's manual before performing any maintenance operation.</p>
3		<p>Thrown or flying objects hazard. Keep a safe distance from the machine.</p>
4		<p>Rotating knives: severing of lower limbs hazard. Keep a safe distance from the machine.</p>
5		<p>Cutting of fingers or hand hazard. Wait until all machine components have completely stopped before touching them.</p>
6		<p>Rotating belts: fingers or hand entanglement hazard. Do not open or remove safety shields while engine is running.</p>
7		<p>Crushing hazard. Stay clear of draft link lifting range while in operation.</p>

8		<p>Implement input driveline: body entanglement hazard. Do not open or remove safety shields while engine is running.</p>
9		<p>Before engaging the tractor PTO, check that rpm rate and sense of rotation are those prescribed for the implement.</p>
10		<p>Lower limbs crushing hazard. Keep a safe distance from the machine.</p>
11		<p>Crushing hazard. Do not stand rear the machine.</p>
12		<p>Hydraulic lines under pressure: keep safe distance. Before carrying out maintenance operations, ensure the line has been previously depressurised and does not contain any hot fluid</p>
13		<p>Always wear protective clothing and equipment appropriate for the job: hearing protection, safety shoes, safety gloves, safety glasses and overall.</p>

4. SET UP

The flail mower is delivered equipped with a driveshaft and related operating manual.

When the machine is delivered, check that there is no damage to the flail mower or driveshaft. In case of damage or missing parts immediately notify the Manufacturer or your Dealer.

Because of his size, the machine could be delivered with some parts to be assembled.

In this case, the assembly of such parts is an owner's task, and must be performed carefully, with reference to the tables of the Spare parts section.



WARNING

For proper tightening torques of bolts and screws, refer to the table in this manual.

4.1. CONNECTING TO THE TRACTOR

The flail mower is designed to be mounted on tractors equipped with 3-point Hitch Category I (ISO 730 standard).

To connect the flail mower to the tractor the operator must do the following:

- drive the tractor in reverse, up to align the rear lifting arms to lower hitches of the flail mower in parking (see picture below);

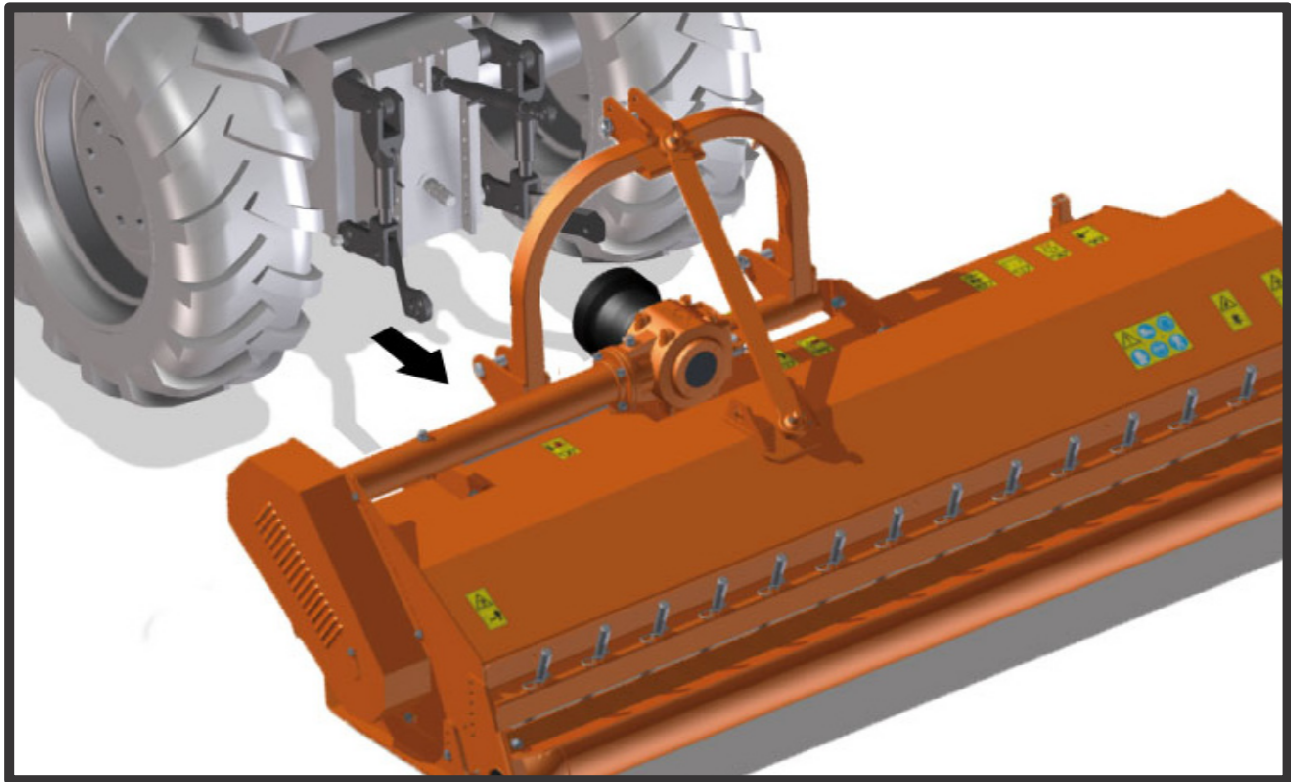

- set the tractor's parking brake, stop engine, remove the ignition key and get off the tractor;
- connect the lifting arms of the tractor to the lower hitches of the flail mower, and the 3-point top link to the upper hitch of the flail mower, through the use of the pins and the relative safety split pins;
- raise the flail mower until PTOs of tractor and machine are at the same height, then adjust the 3-point top link so that the front of the machine is leveled to the back (the axis of the flail mower PTO must be parallel to the ground), in order to limit stress transmitted to the flail mower through the cardan shaft;
- make sure that left side of the flail mower is leveled with the right, by adjusting the tractor lifting arms, then lock the arms to prevent swinging that could compromise the stability of tractor and machine;

- finally adjust the parking stand, placing it at the highest point by means of the related elastic pin.

**WARNING**

Before connect the flail mower to the tractor, make sure that tractor and flail mower are on a flat, stable and dry surface

4.2. DRIVELINE INSTALLATION

The gearbox unit is equipped with a free wheel inside, able to absorb the rotor inertia during stop- ping, and to prevent possible damage to the transmission system machine-tractor that would be caused by an instantaneous stop of the rotor.

Consequently, the use of a cardan shaft with free wheel is not required.

Before installing the driveshaft, the operator must read the manuals of driveshaft and tractor, checking in particular that rpm and direction of rotation of the tractor PTO match those of the flail mower. If the direction of rotation of the PTO tractor does not match that of the machine, contact the Manufacturer or your Dealer.

To connect the driveshaft to the tractor and implement, the operator must:

- park tractor and flail mower on a flat surface, with parking brake set, engine off, and ignition key removed;
- check that driveshaft, flail mower and tractor are in good condition, otherwise provide for their replacement;
- remove the PTO shield of the flail mower through the fixing screws;
- insert the driveline yoke on the implement PTO by first lining up the splines, then ensure its tightening onto the shaft through its fastener/snap pin;
- replace the PTO shield of the flail mower through the fixing screws;
- insert the driveshaft yoke on the tractor PTO, then ensure its tightening onto shaft through its fastener;
- hook to the tractor and flail mower the two retaining chains of the driveline shielding, to prevent shielding rotation during functioning of the machine.

DRIVELINE LENGTH CHECK

Before operating the flail mower, ensure that the size of driveshaft is adequate. The driveshaft supplied with the machine has a standard length, therefore it may need an adaptation of the length, depending of the tractor which the flail mower is combined.

The length of the driveshaft must be such to:

- avoid bottom out of the transmission tubes, when the driveshaft is in compressed position (when flail mower is raised up off the ground);
- ensure an overlapping of the transmission tubes enough to transmit the torque required, when the driveshaft is in max extension (when flail mower is in its lowest position in the ground).

When the driveshaft is at its minimum length (max compressed position), there must be at least a 2 cm of distance between the ends of each transmission tube and the yokes side.

When the driveshaft is at its maximum operational extension, there must be an overlap between the tubes profiles of 15 cm at least.

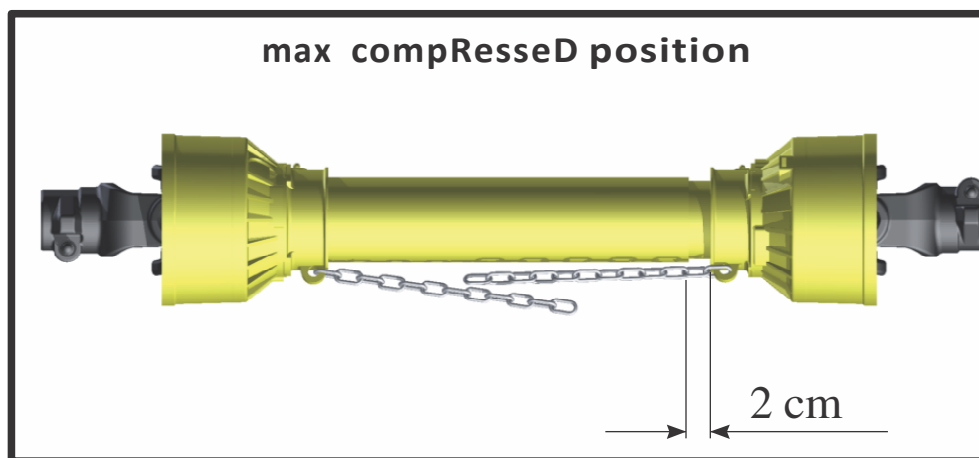
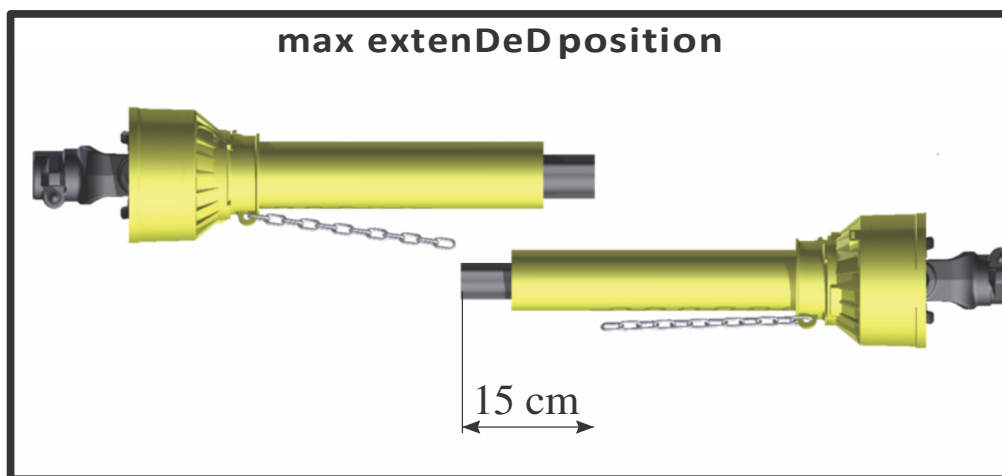

A driveshaft too long may cause structural damages to the tractor and machine. If the driveshaft is too long, it may be adapted by removing it and shortening the tubes according to the instructions provided by the Manufacturer in its use and maintenance manual.

A driveshaft too short can cause disengage of the tubes during operation, with severe hazard for the operator and structural damage to the tractor and machine. If the driveshaft is too short, it must be replaced with a longer one. In this case contact the Manufacturer or your Dealer.

IMPORTANT

- before operating the flail mower the first time, make sure that the driveshaft is lubricated in accordance with how indicated in the instruction booklet;
- before operating the flail mower the first time, and after long periods of inactivity, make sure that the driveline clutch has run a short "run in" in accordance with what indicated in the instruction manual of the Manufacturer, removing the possible oxidation of the components that may compromise the correct slipping during the usage (see also section "Maintenance");
- always engage the tractor PTO at low rpm to minimize the effect of the peak torque on the driveline and the machine.

4.3. TRACTOR-FLAIL MOWER STABILITY

The weight of the machine modifies the stability of the system tractor-flail mower, resulting in loss of steering control and braking.

The front axle of the tractor should always be loaded with at least 20% of the overall weight of the system tractor-flail mower.

**CAUTION**

Check the lifting capacity and stability of the tractor making sure the following relations are complied with (see table below for definitions):

- $M \times (S1+S2) \leq 0.2 \times T \times i + Z \times (d+i)$
- $M \leq 0.3T$

If this not occurs, apply the front ballast required. To determine the appropriate characteristics of the ballast, refer to the manual of the tractor.

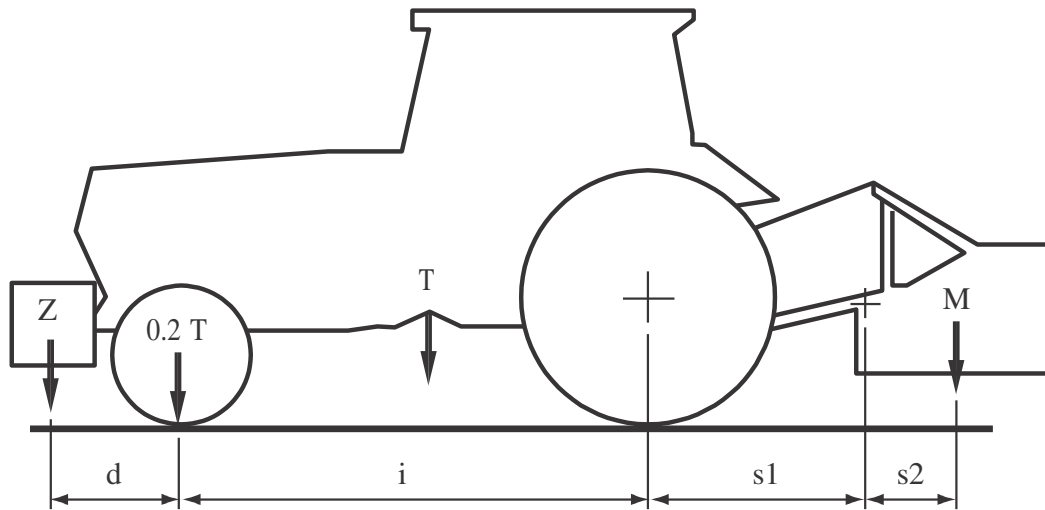

- i = Tractor wheelbase (cm)
- d = Distance between front axle and ballast center of mass (cm)
- T = Weight of tractor + operator (75 kg)
- Z = Ballast weight (kg)
- M = Implement weight (kg)
- $s1$ = Distance between rear axle and lower hitch points (cm)
- $s2$ = Distance between lower hitch points and implement center of mass = 61 cm

5. OPERATING

Before operate the flail mower, make sure you have read and understood the operating manuals of the flail mower, tractor and PTO shaft, and followed what is described in the section "Set Up".

**DANGER**

During operation, adjustment, maintenance, repairing or transportation of the machine, the operator must always use appropriate Personal Protective Equipment (PPE).

Before starting work, ensure that all machine guards are in good conditions and fully functional.

During operation, the machine can throw material from the back: prevent people and animals to approach the operational area.

5.1. START-UP

**WARNING**

Before conducting the above inspections and service, make sure the tractor engine is off, all rotation parts are completely stopped and the tractor is in park with the parking brake engaged. Make sure the machine

is resting on the ground or securely blocked up and the tractor lifting hydraulics locked.

Before the start up and before each use, perform the following pre-operation inspections and service of the implement:

- check that the machine has not damaged functional parts and has all mechanical parts in good condition. Repair and / or replace the damaged parts;
- check that the machine has no missing parts (pins, safety pins, plugs oil ...). Restore the missing parts;
- check that all guards and safety devices have no damages and are properly positioned. Repair and / or replace the damaged shieldings, restore the correct position;
- verify that the PTO driveshaft is properly installed (see section: Connection of the drive shaft);
- check that the driveshaft clutch is in good condition, and that its components are not subject to "sticking" (see sections: Maintenance / Driveline);
- check the presence of lubricant in all greasing points of the machines (driveshaft, supports...) (see sections: Maintenance / Driveline and Maintenance / Support rotor);
- check for oil leaks from the gearbox or the transmission side cover. Identify the reason of loss, then repair and / or replace the damaged components;
- check the correct oil level in the gearbox and in transmission side box (see section maintenance);
- check that the drive belts are in good condition.
- check that blades are not excessively worn and the relating hardware is correctly tightened (see section Maintenance);
- check that all the machine hardware is properly tightened. Refer to the tightening table in the manual for proper torque values;
- check that all safety decals are correctly positioned, in good condition and legible. Replace any damaged decals;
- check that there is no constraints that may prevent the movement of equipment. Remove any constraint.

Before the start up and before each use, make the following checks on the operating area identified for shredding:

- check that area is clear of foreign objects (rocks, branches or debris). Remove any obstacle and visibly highlight obstacles that cannot be eliminated (e.g. by means flags);
- make sure in the working area exposed there are no people or animals;
- make sure the soil to be worked is not too grassy, muddy, sandy or rocky.

Once all the checks above have been done, start the tractor and the flail mower as follows:

- start the tractor and engage the PTO at low rpm, making sure that the flail mower is NOT in the raised position but close to the ground, then increase the speed engine until to 540 rpm;
- lower the machine on the ground and simultaneously start driving the tractor at low speed. Subsequently increase the ground speed depending on ground conditions;
- if the environmental temperature is extremely cold, it's recommended to wait a few minutes with the PTO of the tractor at low rate before lowering the flail mower completely on the ground;
- drive for a while operating the flail mower, then stop the tractor to check the quality of the work performed. If you need to get off the tractor, lift the flail mower just out of the ground, reduce engine speed and disengage PTO, set the parking brake, stop engine and remove the ignition key.

If the cutting height and/or the quality of the shredding are not as desired, correct them by adjusting the roller or the wheels (see sections "Adjustments").

5.2. OPERATING INSTRUCTIONS

During operations:

- always keep the tractor engine at rpm rate ensuring to the flail mower the right power required for the
-

use;

- always keep a tractor speed adequate to working conditions (from 2 to 10 km/h approx.). Reduce speed in the case of hard or stony soils;
- choose a driving pattern that provides the maximum pass length and minimizes turning;
- when working in the hills, if you can do "climbing" in the sense of the slope, in any case do not work along the hillsides, making the steps from top to bottom to reduce the terrace. Where possible always try to «work up» the slope. If this is not possible avoid hoeing along the contours of the hill and hoe up and down the slope to avoid a terracing effect;
- always perform changes and reverse of direction with PTO disengaged and the flail mower slightly lifted from the ground to avoid damage to the machine;
- periodically check for foreign objects wrapped around the rotor shaft and remove them, after disengaging PTO, turning off tractor engine, and removing ignition key;
- if the rotor strikes a foreign object, stop operating immediately, idle the engine speed and disengage the PTO. Wait for stopping of all rotating parts, then raise the implement and proceed to check and remove the object, after stopped the tractor, set the parking brake, stopped engine and removed the ignition key. Repair any damages immediately, and make sure rotor is in good condition before restarting operation;
- avoid overheating of the gearbox due to materials extremely difficult to shred, in order to avoid damages of the gearbox.

Typical problems that may occur operating the flail mower are described into Troubleshooting section, together with their solutions.

5.3. ADJUSTMENTS



WARNING

All adjustment operations must be performed with the tractor engine off, the PTO disengaged, the flail mower lowered to the ground or on security stands, the parking brake set and the ignition key off.

CUTTING HEIGHT ADJUSTMENT

The cutting height of the flail mower is determined by the vertical position of the rear roller (or the pivoting wheels) on the machine.

Lifting up the roller (or the wheels) the tools of the rotor get closer to the ground, reducing the cutting height. On the contrary, lowering the roller (or the wheels) the tools increase their distance from the ground, increasing the cutting height.

After a change of the working height, make sure that the tools of the rotor are not interfering with the soil: a direct contact with the ground would facilitate the rapid wearing of the tools.

If the flail mower is provided with a stabilizer roller, to adjust the cutting height:

- lift the flail mower, put it on safety stands, then turn off the tractor engine, disengage the PTO, set the parking brake and remove the key from the panel;
- remove the bolts (1) that secure the roller supports to the frame on both sides;
- position the roller according to the height required;
- Replace and tighten the bolts (for the correct torque value refer to the torque table of the manual).

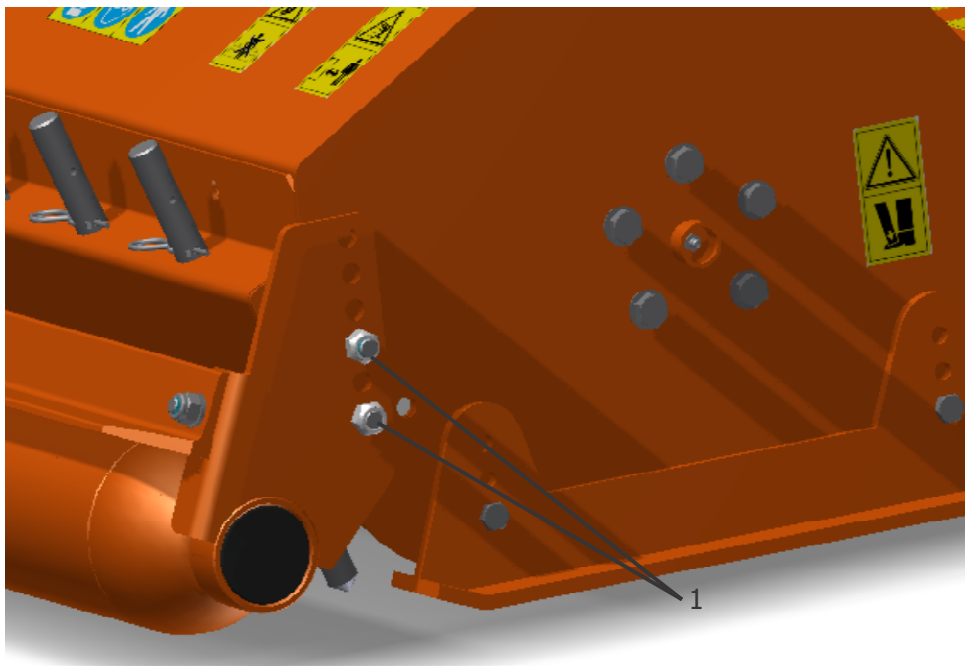

Depending on the different roller positions, it is possible to set four different cutting heights: 32-57-82 and 107 mm.

When finished, make sure that the roller supports are positioned at the same height, and check, with the flail mower resting on the ground, that the front of the machine is leveled with the back. If necessary, adjust the level through the 3-point top link of the tractor.

If the flail mower is provided with the pivoting wheels, to adjust the cutting height (see picture):

- lift the flail mower, put it on safety stands, then turn off the tractor engine, disengage the PTO, set the parking brake and remove the key from the panel;
- while holding up vigorously the wheel with bracket, remove the snap pin (1);
- remove the wheel with bracket and spacers (2) that determine the cutting height;
- insert one or more spacers in the lower part of the shaft of the bracket. The number of the spacers shall be based on the increase of the cutting height desired;
- reposition the wheel with bracket into the original place, and put the remaining spacers on top of the shaft;
- reinsert the snap pin;
- repeat the same procedure to the opposite wheel, making sure the spacers are positioned exactly like on the first wheel.

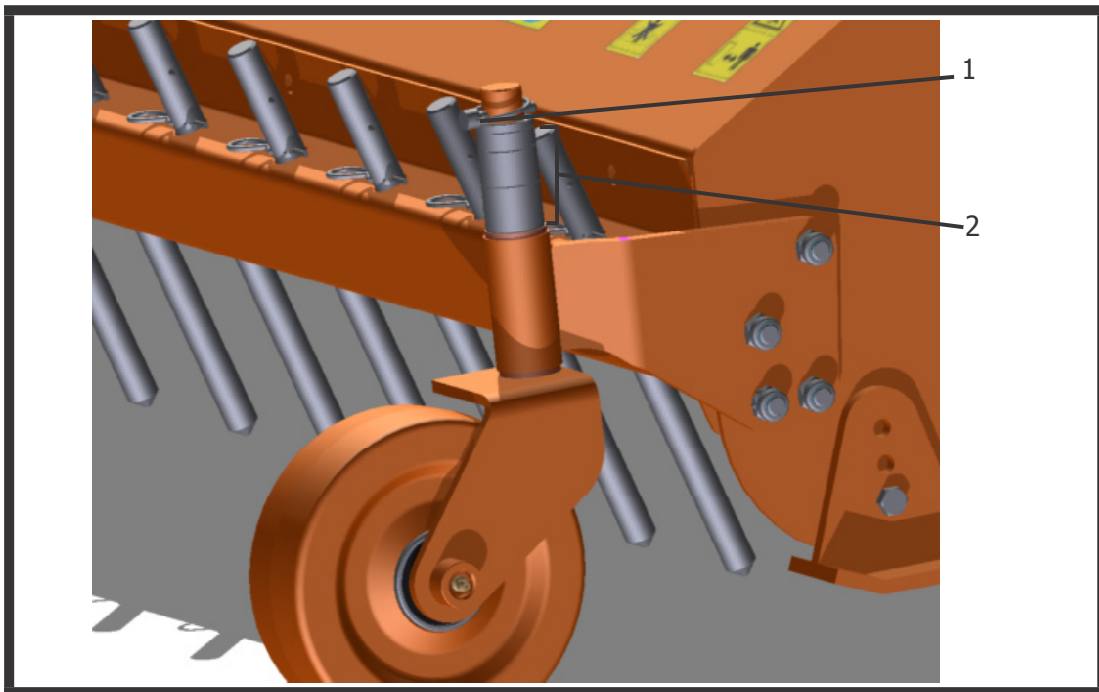

Depending on the different position of the spacers on the shaft, it is possible to set five different cutting heights: 70-76-89-114 and 145 mm.

When finished, make sure that the pivoting wheels are positioned at the same height, and check, with the flail mower resting on the ground, that the front of the machine is leveled with the back. If necessary, adjust the level through the 3-point top link of the tractor.

SKID ADJUSTMENT

The position of the skids can be adjusted by:

- loosening and removing the bolts (1) that clamp the skids to the side plates of the frame,
- reposition the skids according to the needs, and
- retightening the bolts (1).

The skids can be placed in 3 different positions but, in the presence of the stabilizer roller or the pivoting wheels, they have the unique function of protecting the side plates of the frame from any direct contact with the ground.

Therefore, make sure the skids are not positioned below the roller or wheels, because the latter two are the devices holding the flail mower lifted off the ground (and not the skids).

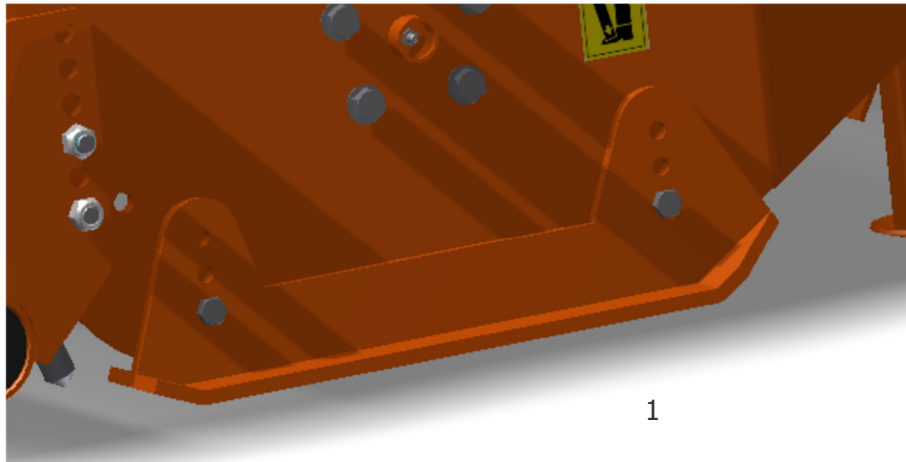

RAKES ADJUSTMENT

The function of the rear rakes is to obtain a more fine crushing by holding the material within the shredding room.

It is therefore recommended to perform the rakes adjustment immediately after executing the cutting height adjustment.

To do this follow these steps:

- remove the cotter pin (1) from one of the rakes;
- push the rake downwards in order to retain more material inside the shredding chamber and obtain a more fine crushing. Vice-versa, pull the rake upwards to retain less material inside the shredding chamber and to obtain a more coarse crushing;
- insert the split pins (1) on the hole of the rake closest to rear bar, after setting the desired position;
- repeat the procedures adjusting all other rakes to the same height of the first one.

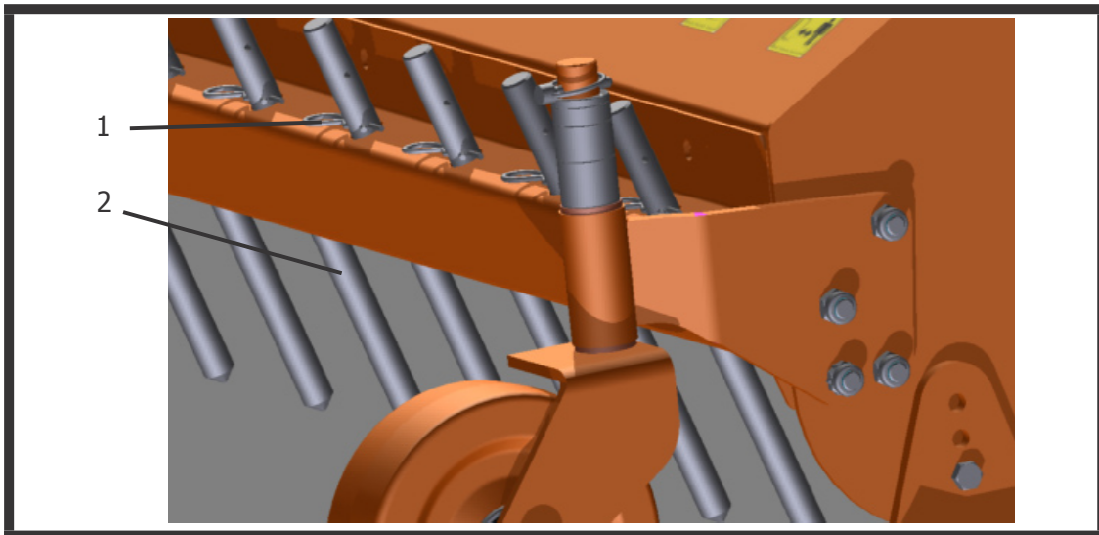

SIDE SHIFTING ADJUSTMENT

The SFM flail mowers can be configured with mechanical or hydraulic shifting device.

In case of mechanical shifting device, to shift the side position of the machine, act as described below:

- lift the flail mower, then turn off the tractor engine, disengage the PTO, set the parking brake and remove the key from the panel;
- unscrew and remove the bolt (1);
- manually move the body of the flail mower by pushing from one side, until it is reached the position required overlaying the holes of the mechanical jack;
- reinsert the bolt removed earlier and tighten.

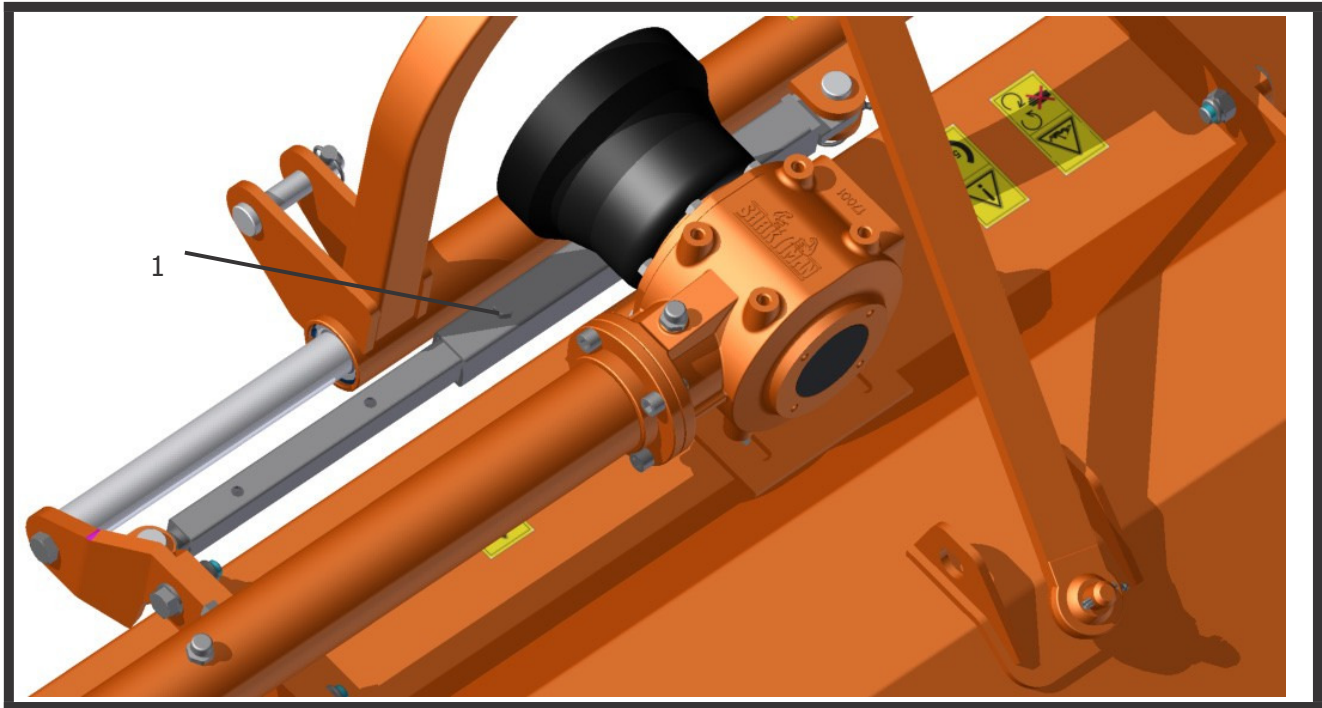

In case of configuration with hydraulic cylinder, the side adjustment of the frame is effected by actuating the cylinder directly by the hydraulic control system of the tractor, after performed the connection of the machine hydraulics to the tractor.

BELT TENSIONING ADJUSTMENT

To check the correct belt tensioning of the side transmission,

- remove the safety cover of the belts by loosening the four bolts (1) that secure it to the frame (see picture):
- Check the correct belt tension.

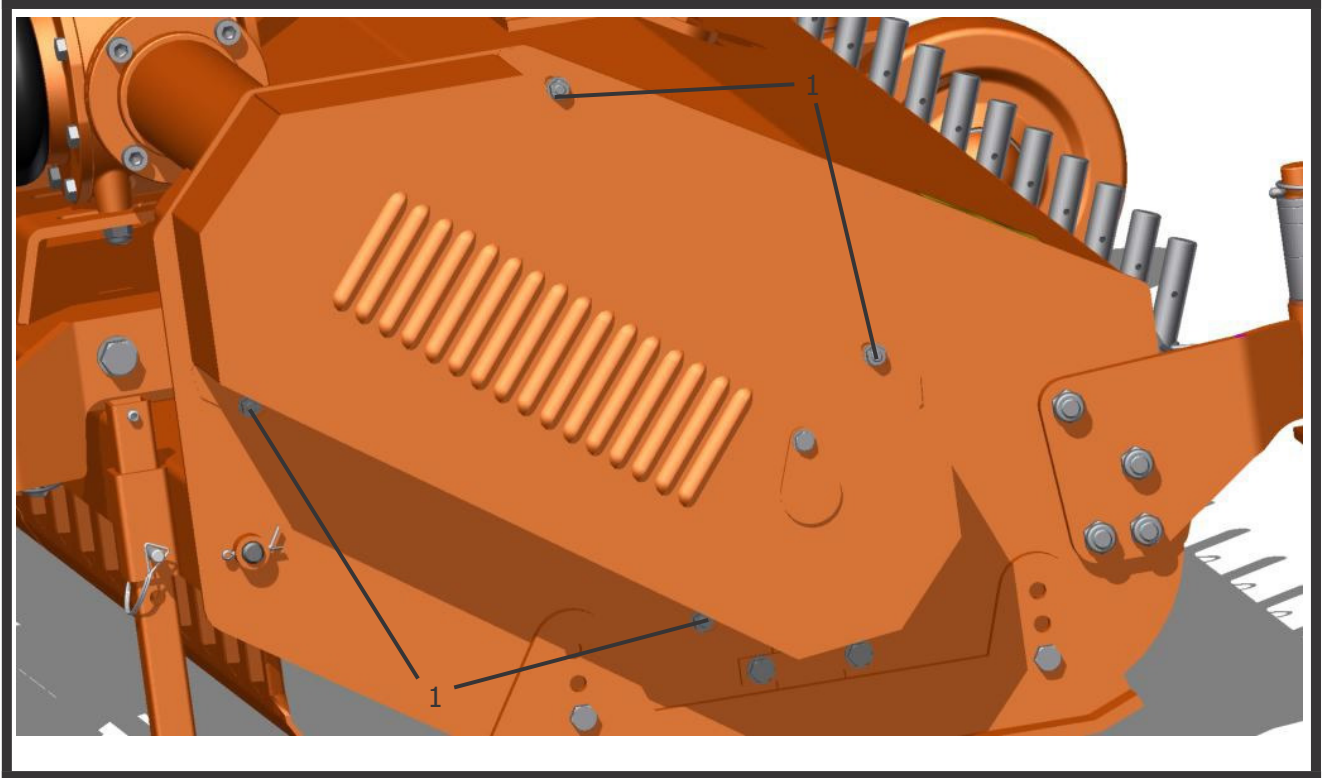

Apply a force of about 10-15 kg on the middle of the belts set, and measure the entity of the consequent deflection of the belts (see picture):

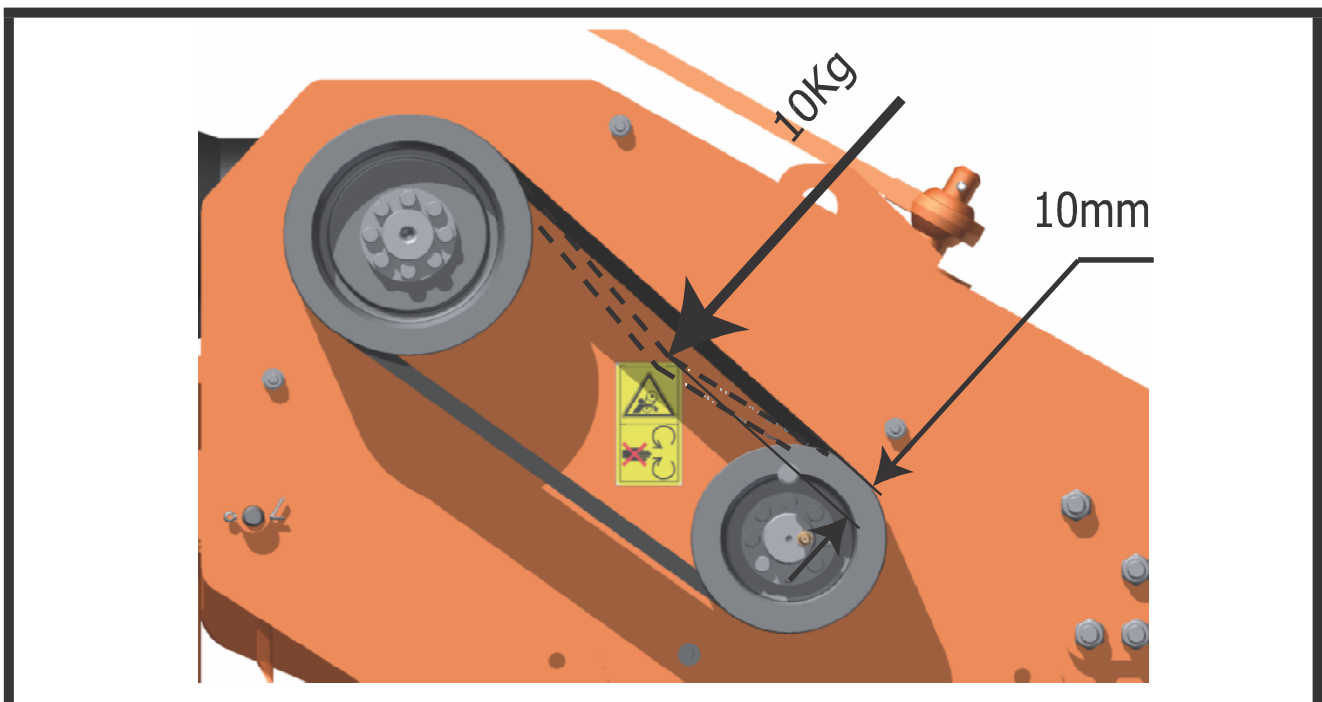

If the deflection is about 10 mm, the tension is correct.

If is not so, proceed with the adjustment in the following way (see picture below):

- loosen the four nuts (1) under the gearbox which lock it to the frame;
- loosen the two bolts (2) fixing the extension tube to the side plate of the frame;
- while holding the screw (3), loosen the lock nuts (4);
- tighten the tension nut (5) if the tensioning found is too low (deflection of belts higher than 10 mm); unscrew the tension nut (5) if the tensioning found is too high (deflection of belts lower than 10 mm).
- retighten the lock nuts (4) and the two bolts (2) fixing the extension tube to the side plate of the frame;
- move the gearbox in order to restore the position of the extension tube perpendicular to the side plate of the flail mower;
- retighten the four nuts (1) under the gearbox;
- reposition the safety cover in his original place.

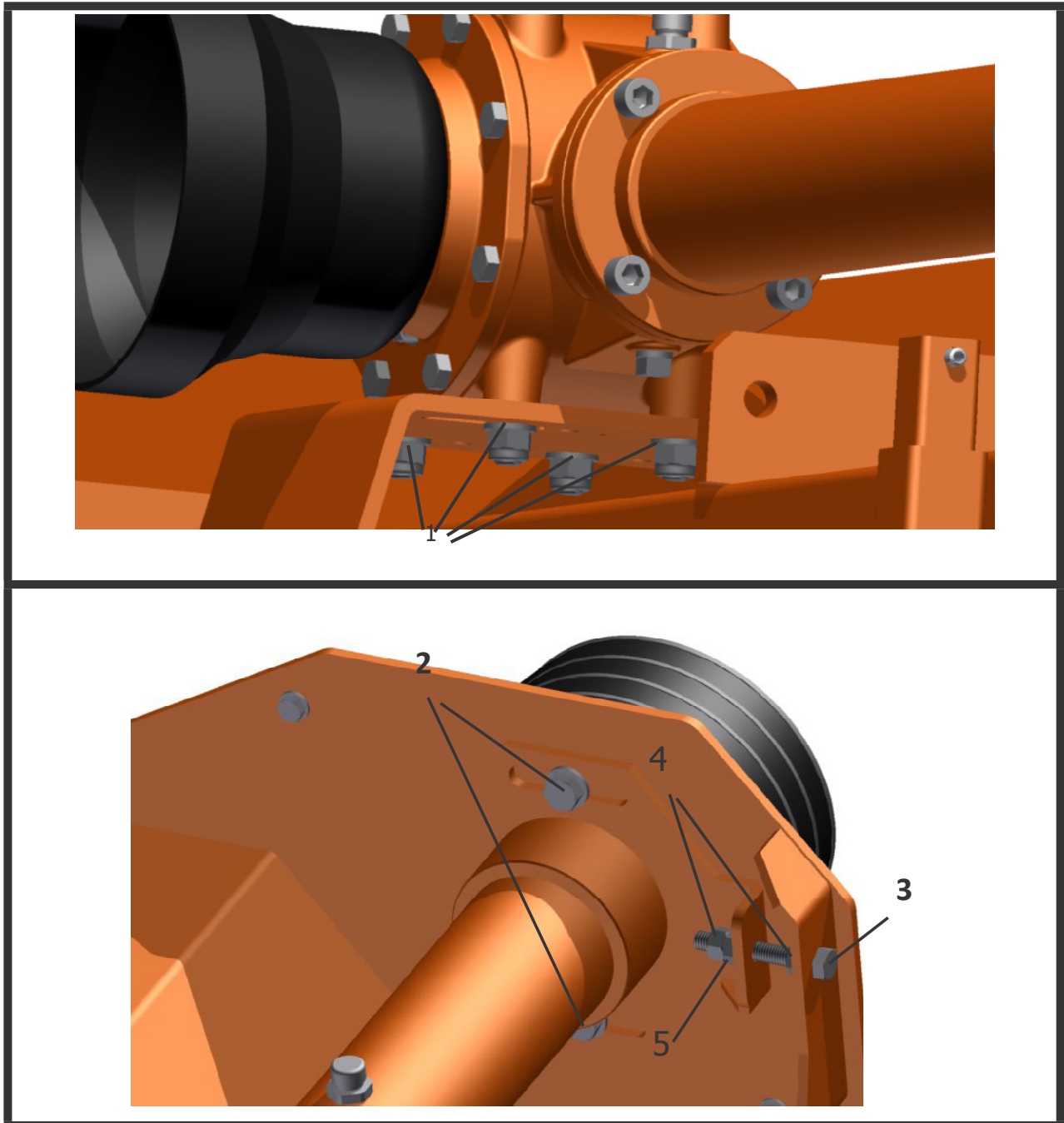

If the replacement of the set of belts is required:

- remove the safety cover of the belts by loosening the four bolts that secure it to the frame
- loosen the four nuts (1) under the gearbox which lock it to the frame;
- loosen the two bolts (2) fixing the extension tube to the side plate of the frame;
- loosen the lock nuts (4) and the tension nut (5) until the extraction of the belts from their seats on the pulleys is permitted, starting from the external position (a)
- reinsert the new belts in succession contrary to what done for the disassembly.
- adjust the belt tension according to the indications done above
- retighten the two bolts (2) fixing the extension tube to the side plate of the frame;
- move the gearbox in order to restore the position of the extension tube perpendicular to the side plate of the flail mower;
- retighten the four nuts (1) under the gearbox;
- reposition the safety cover in his original place.

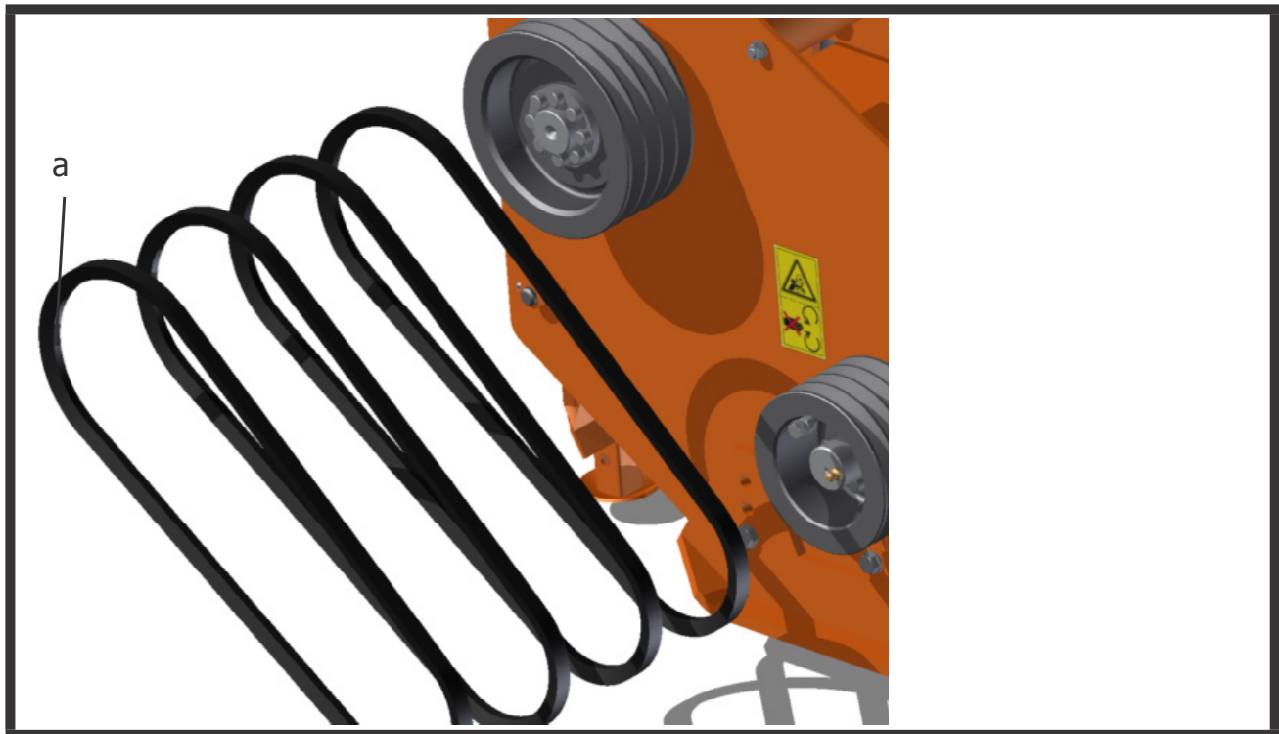

5.4. STOPPING AND DISCONNECTION

To stop the flail mower at the end of a working session:

- bring the tractor to a complete stop;
- place the transmission in park or neutral;
- reduce the engine speed, then disengage the PTO;
- wait for stopping of all rotating parts;
- lower the implement to the ground;
- set the parking brake;
- shut down the engine and remove the key before exiting the tractor;
- do the cleaning and maintenance required to make the machine ready for later use (see section Maintenance).



WARNING

Never leave the tractor unattended with the implement in the lifted position.

To disconnect the flail mower from the tractor (e.g. to make a change of implement):

- adjust the parking stand to the lowest position, through the use of relative retaining pin;
- park the tractor on a dry and level surface;
- reduce the engine speed, then disengage PTO;
- wait for stopping of all rotating parts;
- lower the implement to the ground;
- set the parking brake;
- shut down the engine and remove the key before exiting the tractor;
- place safety blocks under flail mower to prevent unit from tipping over onto a child and/or an adult. A Flail mower that tips over can result in injury or death;
- disconnect the driveline from the tractor PTO and rest it on the provided support of the flail mower;
- disconnect the top link and rear lifting arms of the tractor from the flail mower hitches;
- check the flail mower stability. If needed, place additional safety blocks;
- get on the tractor, start the engine and move away from the flail mower slowly;
- make sure the flail mower remains stored in a protected area, to prevent that unauthorized personnel can approach it.

Before a long term storage (e.g. at seasonal end), do cleaning and maintenance operations as specified in sections MAINTENANCE and STORAGE.

5.5. TRANSPORTING

To set the flail mower for transportation, perform the following steps:

- idle tractor engine, disengage tractor PTO, and wait for stopping of all rotating parts;
- lift the flail mower until the transport position, making sure the driveline transmission tubes does not contact tractor or flail mower. A minimum gap of 2 cm should be leaved between the tubes and tractor and flail mower (see also section Driveline installation);
- lock the tractor lifting hydraulics, turn off the engine, set the parking brake, remove ignition key and get off the tractor;
- adjust the parking stand to the highest position, through the use of relative retaining pin, to prevent its possible damage during transport.

When driving on public roads, follow strictly all local laws and traffic regulations.

**WARNING**

When driving on public roads, reduce your speed, be aware of traffic around you and proceed in such a way that faster moving vehicles may pass you safely.

6. MAINTENANCE

Proper and regular maintenance ensures a long life of the equipment, avoids failures and saves time and repair costs.

Periodic inspections and maintenance operations described in this section must be performed by operator in the times and terms prescribed. Failure to comply with maintenance prescriptions can compromise the functioning and duration of the machine, and consequently invalidate the warranty.

The frequency of maintenance indicated refers to normal conditions of use: it must be intensified in severe operating conditions (frequent stops and starts, prolonged winter season etc ...).

Repairs, maintenance and modifications other than those mentioned in this paragraph should NOT be performed without consulting the Manufacturer or your Dealer. Manufacturer, as the case, may give the authorization to proceed with the repair together with all necessary instructions.

Wrong or inappropriate repairs or maintenance may generate abnormal operating conditions, equipment damage and generate risks for the operator.

**AVVERTENZA**

For safety reasons, all maintenance operations must be performed with tractor PTO disengaged, flail mower stopped and completely lowered to the ground or onto support blocks, parking brake set, tractor engine shut off, and ignition key removed.

IMPORTANT

Respect the environment. Store or dispose of unused chemicals as specified by the chemical Manufacturer.

6.1. ROTOR TOOLS REPLACEMENT

Frequently check the wear condition of the tools on the rotor (Y blades or hammers) through visual inspection. The wear of the tools is very variable depending on the type of soil.

Replacement of the tools is necessary when the operator notices increase of power absorption during operations, or when the blades or hammers dimension is significantly reduced compared to the original.

The use of the machine with tools in bad condition compromises the quality of the work.

Before perform replacement of the blades:

- idle tractor engine, set the parking brake, disengage tractor PTO, and wait for all moving parts to come to a complete stop;
- place the machine slightly lifted from the ground on safety blocks or mechanical stands;
- lock the control lever of the hydraulic lift of the tractor;
- turn off the tractor and remove the key from the control panel.

To perform the replacement of blades:

- remove the bolt that locks the couple of Y blades (or the hammer) in the rotor. For the Y blades, two bushing are placed on the bolt to fill the gap between the blades and the holders of the rotor;
- place the new tool instead of the one worn out, and tighten the bolts with washers, referring to the torque values shown in "Table torques" in the manual. Be sure to install the cutting edge facing in the direction of rotation of the rotor. For the rotor with Y blades do not forget to place the related bushings between the blades and the holders.
- repeat the same procedure for all the Y blades (or hammers);

- repeat this process for all the tools.

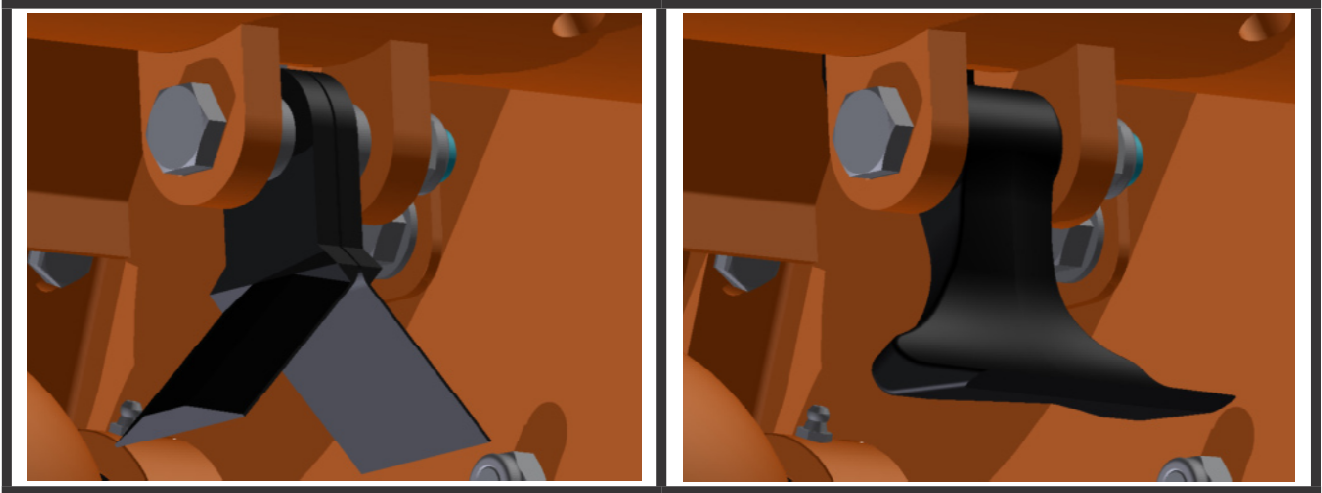

IMPORTANT

Remove and install one blade/hammer at a time to ensure blades/hammers are correctly oriented when installed.

Replace worn blades only with original parts.



WARNING

When the blades/hammers are worn out it is necessary to replace the full set of tools.

Replacement of only some of the tools is certainly cause of the rotor unbalance, machine vibrations and can compromise the reliability of the flail mower and generate risks to the operator.



CAUTION

Worn blades and hammers may be very sharp!

6.2. GEARBOX LUBRICATION

Lubrificant: AGIP ROTRA MP SAE 85W/140 oil gear or equivalent



CAUTION

Before touching the gearbox wait until it has cooled sufficiently.

Check the oil level every 50 hours, making sure the level is aligned with the level plug (1).

To perform the check, it is necessary to remove the screws (2) holding the safety cover on the gearbox, which prevents access to the plug.

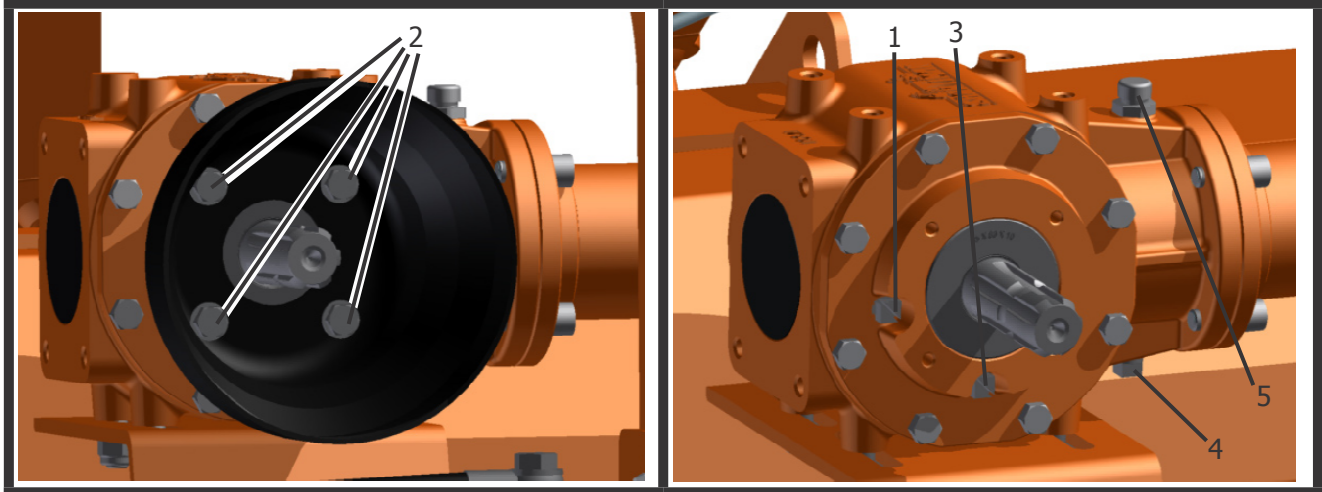

If the oil level is below the line of the level plug, it's necessary fill up oil till restore the correct level.

The oil change must be performed:

- after the first 50 working hours;
- each 500 working hours.

To make the oil change:

- unscrew the level plug (1);
- place a tank under the oil drain plugs (3) and (4);
- unscrew the oil drain plugs (3) and (4) and drain oil completely into the tank;
- retighten the drain plug (4);
- unscrew the oil filling plug (5) on the top of gearbox;
- fill up oil till the level reach the hole of the level plug (1);
- retighten level plug (1) and the filling plug (5);
- replace the safety cover retightening the screws (2);
- dispose the discharged oil into containers for used oil.

IMPORTANT

Frequently check possible oil leaks from the flail mower through visual inspection, and in case of leakage provide immediately proper maintenance.

Avoid oil leaks on the ground when restoring oil level or making oil change.

6.3. ROTOR BEARINGS LUBRICATION

Lubricant: AGIP GREASE MU EP 2 lithium-type grease (or equivalent)

Frequency: each 20 working hours

Lubricate with multipurpose lithium-type grease through a manual grease pump, after meticulous cleaning of grease nipples.

To perform lubrication (see pictures):

- turn the cover (1) and inject grease through the nipple (2);
- inject grease through the nipple (3).

IMPORTANT

Make sure to clean the fitting zerk before using the grease gun.

Do not let excess grease collect on or around parts, particularly when operating in sandy areas.

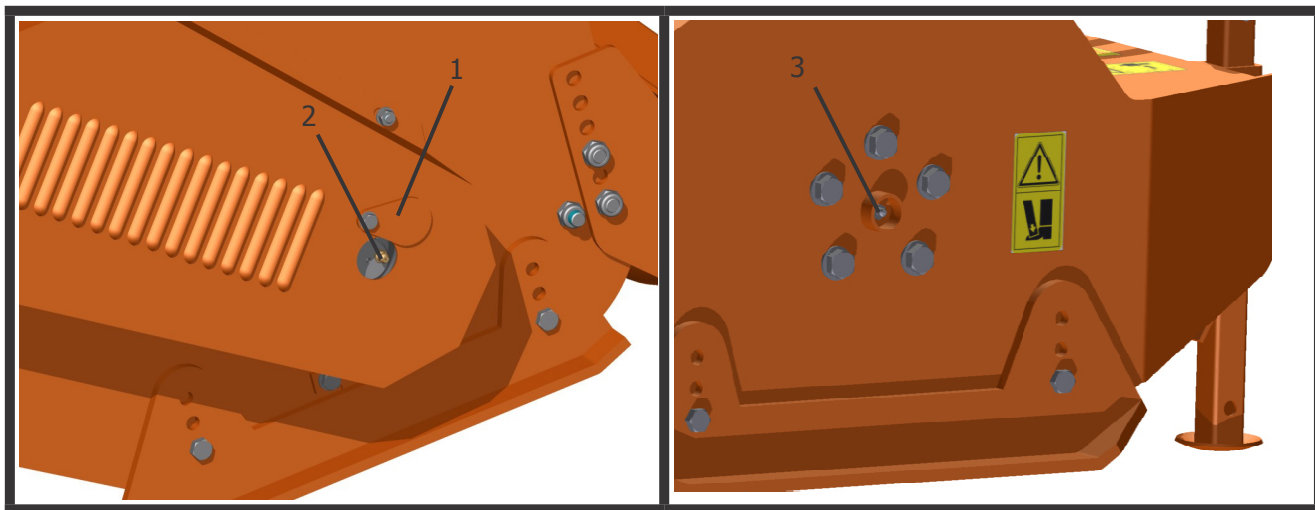

6.4. ROLLER BEARINGS LUBRICATION

Lubricant: AGIP GREASE MU EP 2 lithium-type grease (or equivalent)

Frequency: each 20 working hours

To perform lubrication, inject grease into the nipples (1) and (2), located on the upper part of the roller bearing supports (see pictures).

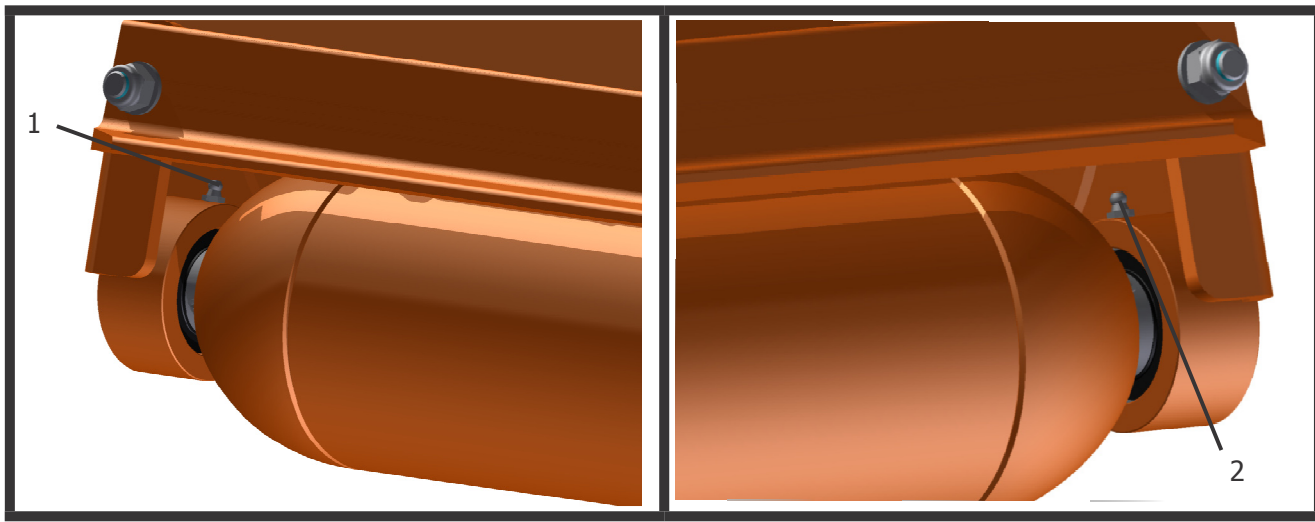

6.5. WHEELS BRACKETS LUBRICATION

Lubricant: AGIP GREASE MU EP 2 lithium-type grease (or equivalent)

Frequency: each 20 working hours

To perform lubrication, inject grease into the nipple (1), located on the inner part of the wheel bracket (see picture).

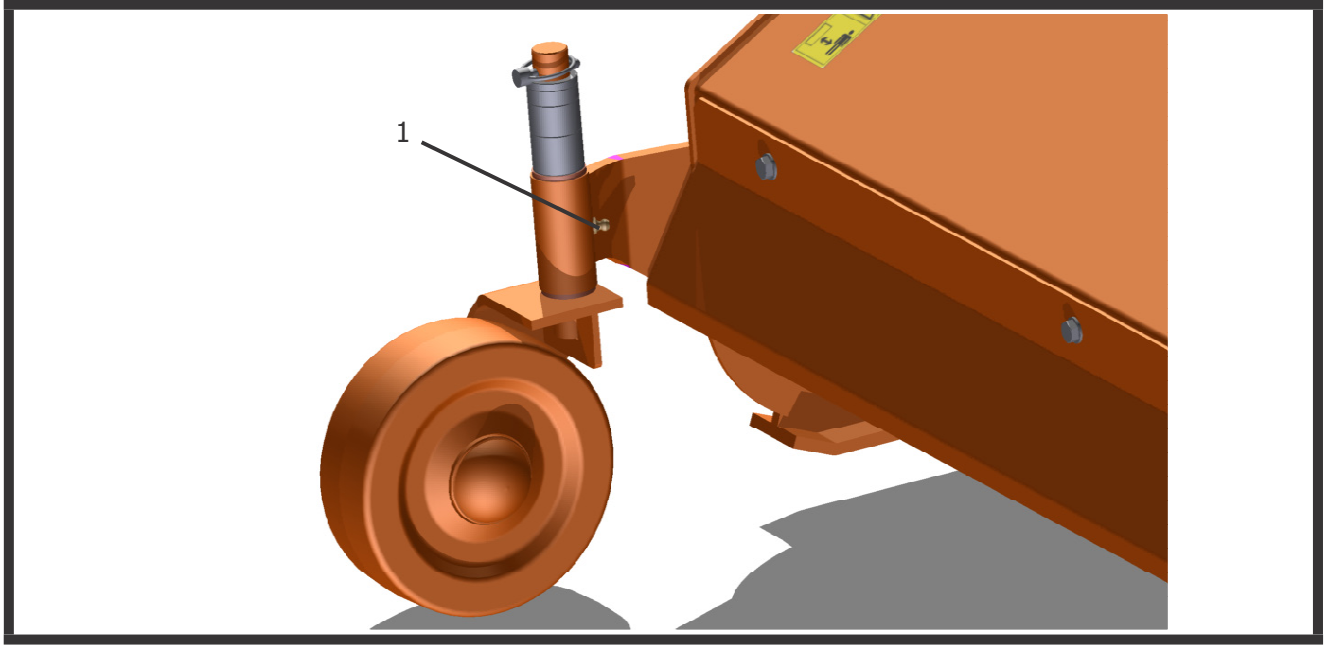

6.6. 3-POINT HITCH LUBRICATION

Lubricant: AGIP GREASE MU EP 2 lithium-type grease (or equivalent)

Frequency: each 20 working hours

To perform lubrication of the shifting parts of the 3-point hitch (see pictures):

- inject grease into the nipples (2), located on the lower part of the shifting tube of the hitch;
- inject grease into the nipples (3), located on the rod-tie of the hitch.

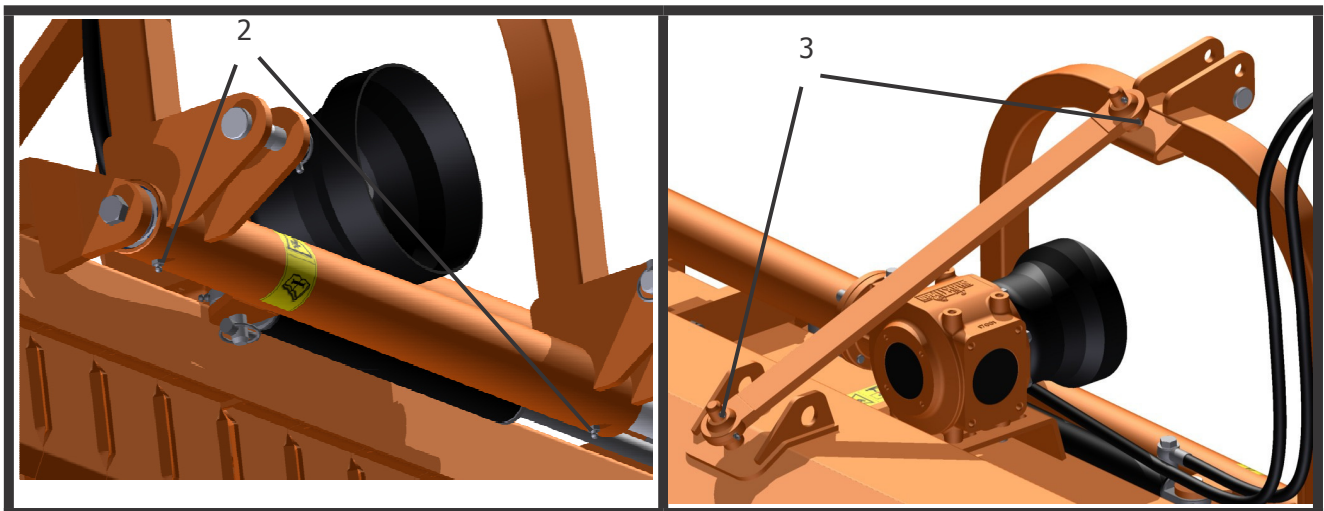

6.7. DRIVE BELTS REPLACEMENT

Frequently check the wear of the belts, and if one or more of these appears worn replace the full set. To replace the drive belts, refer to the section "Belts tensioning adjustment".

6.8. DRIVESHAFT MAINTENANCE

Lubricant: AGIP GREASE MU EP 2 lithium-type grease (or equivalent)

Frequency: each 20 working hours

Grease crosses, sliding parts of protective shielding and driveshaft transmission tubes.

IMPORTANT

For details about maintenance and lubrication of the driveshaft, refer to the user manual of the driveshaft Manufacturer.

NOTE

For the driveshaft service parts, refer to the user manual of the driveshaft Manufacturer.

7. STORAGE

Before leaving the machine unused for a long time, it's necessary to perform following tasks to preserve the appearance and functionality of the machine, and to make easier the restart at later use:

- park the flail mower on a flat surface, in a place dry and protected from exposition to the elements, possibly with storage temperature between 0 and 50 °C (see section Stopping and disconnection);
- thoroughly clean the machine, removing from the rotor all residues due to tillage, in order to avoid damage from grass and stagnant water;
- inspect carefully the machine, checking for worn and/or damaged parts. Perform immediately all repairs and/or replacements needed, in order to make the machine ready for restarting;
- in case of abrasion of painted surfaces, provide restoring the surface protection through touchup paint to prevent rust;
- make sure the safety decals are in their original positions, intact and legible. When required, replace the decals immediately;
- lubricate properly all grease points, and restore the oil levels as indicated in the Maintenance section. Use protective oil to coat the exposed mechanical components and to protect them against rust.

8. SCRAPPING

In case of scrapping, the machine must be disposed in appropriate and authorized sites, according to local legislation.

Before scrapping, separate plastic parts from rubber parts, aluminum, steel, etc.

Recover and dispose any exhausted oils to authorized centers for oil collecting.

9. TROUBLESHOOTING

PROBLEM	POSSIBLE CAUSE	POSSIBLE SOLUTION
Oil leaking from gearbox/ transmission case	<ul style="list-style-type: none"> • Gearbox overfilled • Loose filling/drain/level plug • Damaged breather plug • Damaged seals 	<ul style="list-style-type: none"> • Drain to proper level • Replace breather plug • Tighten filling/drain/level plug • Replace seals
Shredding not uniform	<ul style="list-style-type: none"> • Worn blades/hammers • Roller/wheels set in wrong way • Debris wrapped on rotor • Dirty shredding room 	<ul style="list-style-type: none"> • Replace blades/hammers • Set the roller/wheels correctly • Reduce the ground speed • Clean the shredding room
Gearbox overheating	<ul style="list-style-type: none"> • Low oil level • Material difficult to be shredded 	<ul style="list-style-type: none"> • Add oil • Reduce the ground speed
Blades/hammers wear frequently	<ul style="list-style-type: none"> • Hard soil • Cutting height too low 	<ul style="list-style-type: none"> • Check the soil in advance • Increase the cutting height
Flail mower noise and vibration noticeable and constant	<ul style="list-style-type: none"> • Unbalanced roller • Worn bearings • Blades/hammers worn, damaged or missing 	<ul style="list-style-type: none"> • Balance the roller in authorized shop • Replace bearings • Replace blades/hammers

10. TORQUE VALUES TABLE

Check frequently flail mower hardware to make sure that screws and bolts are tightened according to torque values listed in following table:

	8.8 GRADE	10.9 GRADE
BOLT SIZE (METRIC)	Nm	Nm
M6	11	15
M8	26	36
M10	52	72
M12	91	125
M14	145	200
M16	225	315
M18	310	405
M20	440	610

11. WARRANTY

M/s. Tirth Agro Technology Pvt. Ltd. offer the following warranty to the purchaser of Sundown equipment mentioned herein above subject to the conditions set out herein after provided the Sundown equipment shall be in the possession of and used by such purchaser from the date of delivery.

M/s. Tirth Agro Technology Pvt. Ltd. Warrants its products for a period of twelve (12) months from date of delivery, for manufacturing or material defects only. Failed part will be replaced at its authorized dealers only and any part component there of that shall be examined by them, shall disclose if to be defective. This warranty shall not apply to equipment or parts that have been subject to negligence, or accident, or not maintained as per company instructions specified in operator manual or that have been altered or repaired or used with non-genuine parts or abused or due to contaminated oil or used in not recommended application.

Warranty Terms & Conditions:

- 1) The purchaser of Sundown equipment should strictly follow the instruction given in the instruction manual provided by the company along with the Sundown equipment at the time of delivery. Changes if any, resulting in improper usage will not be covered by the warranty. This warranty will automatically terminate on the expiry of warranty period of Six months even the Sundown equipment may not be in use for any time during the warranty period for any reason whatsoever including any technical reasons and time taken for such repairs/replacement of parts, and in transit, whether under this warranty or otherwise shall not be excluded from the warranty period.
- 2) All wear and tear items like bearings, chains, sprockets, oil seals, tines, blades, rubber parts and gaskets are not covered under warranty.
- 3) All items with normal wear or failure due to normal wear will not be covered under warranty.
- 4) While the company or authorized dealers will make every effort to carry out repairs/replacement of parts under this warranty as soon as possible. It is expressly made clear that the company shall not be liable to do within any specific period of time. In the event of repairs/replacement of any parts, this warranty will thereafter continue to remain in force only for the unexpired period of warranty.
- 5) It is entirely left to company discretion to repair/replacement of parts at the site of delivery or at the authorized service points of its dealers. The defective parts which has/have been agreed to be replaced, should be returned to the company without any further claim.

-
- 6) The warranty shall not cover any consequential or resulting liability, damage or loss arising directly or indirectly out of any defect in the Sundown equipment. This warranty shall be strictly limited to repairs and replacement of the defective parts specified in the warranty, and does not cover any reimbursement of labour charges for any repairs so earned out at dealer/client end.
 - 7) This warranty shall not be extended in any case of replacement or return of the Sundown equipment as a whole. Only failed parts will be covered under warranty.
 - 8) The purchasers of Sundown equipment will itself fully responsible for model/variant selection.
 - 9) This warranty does not cover for statutory duties and taxes like excise, service tax or CST or VAT or State sales tax and octroi and any other local taxes payable on any of the parts which the company may supply or repairs free of cost during the warranty period.
 - 10) This warranty also does not cover the cost of packaging, to and fro freight and transportation charges etc., on the defective Sundown equipment or other parts of the Sundown equipment sent to company's works in Rajkot or to the authorized service station.
 - 11) Warranty becomes void if:
 - a) The Sundown equipment has not been delivered, assembled, started and put into operation by the company or its authorized representative.
 - b) The dully filled delivery certificate is not in our possession within 15 days from the date of delivery.
 - c) The Sundown equipment or any parts thereof is subjected to neglect, fire, floods or other acts of God or if in the company's opinion any damage has caused to the Sundown equipment during transportation.
 - d) The original serial number is removed, obliterated or altered from the unit.
 - e) Any attempt is made to have the repairs executed by a person or persons, other than the company or its authorized representative.
 - f) Any defect is not informed immediately to the company or its authorized representative, any alteration in warranty card is made.
 - g) Whenever the user or anyone else on his behalf applies equipment to the tractor or to prime mover that has not been expressly approved by the manufacturer or not suitable to the equipment.
 - 12)
 - a) Any changes in the location of the Sundown equipment or in the/its ownership thereof during the warranty period must be intimated in writing to the company or its authorized dealer within ten days before the change. Failure to do so will absolve the company from the obligation under this warranty.
 - b) Further, in the case of shifting for the continuation of the Warranty, the Sundown equipment has to be inspected by the company or its authorized representative before shifting from the original location and before using it at the new location. The inspection free levied by the company or its authorized representative as well as the cost of rectification of any damage in transit, detected in the above inspection, shall be borne by the purchaser/owner, if at the time of restarting, the Sundown equipment is found to be in working order, this warranty shall continue to be in force for the remaining period of the warranty.
 - c) Damage to the Sundown equipment or any part thereof caused during shifting or transportation is not covered by this warranty
 - 13) None of the company representative or authorized dealer is authorized to alter/amend any terms and conditions of this warranty policy. Only the management of the company is authorized to do so. The decision of the company will be final and binding to the purchaser.
 - 14) This warranty policy shall be governed by and construed in accordance with the laws of India and the courts in Rajkot shall have exclusive jurisdiction.
 - 15) This warranty is given in lieu of all other guarantees and condition expressed or implied by law or by the any person purporting to act on behalf of the company and excludes every condition, warranty or guarantee not herein expressly set out.
-

Note: The parts/material that are not covered by this warranty are as follows:

- 1) Blades,
- 2) Universal joint cross,
- 3) Paint,
- 4) Bearings,
- 5) Rubber parts,
- 6) Gaskets,
- 7) Fasteners,
- 8) Fabrication,
- 9) Chains & sprockets,
- 10) Tines

12. SPARE PARTS

All repairs and replacements on the machine must be performed only by using original spare parts, which must be obtained from the Manufacturer or your Dealer.

This section contains the information needed to identify the parts of SFM flail mower that may be ordered to Manufacturer.

When request spare parts to Manufacturer, always give following indications:

- type of machine;
- flail mower serial number;
- description and p/number of the spare parts;
- quantities.

NOTE

For identification of p/numbers and description of safety decals refer to the Section Safety labels.

For identification of p/numbers and description of PTO driveline parts, refer to the manual of the driveshaft Manufacturer.

The Manufacturer reserves the right to substitute a required part with an equivalent part, if applicable.

MAIN FRAME & ROTOR ASSEMBLY PARTS

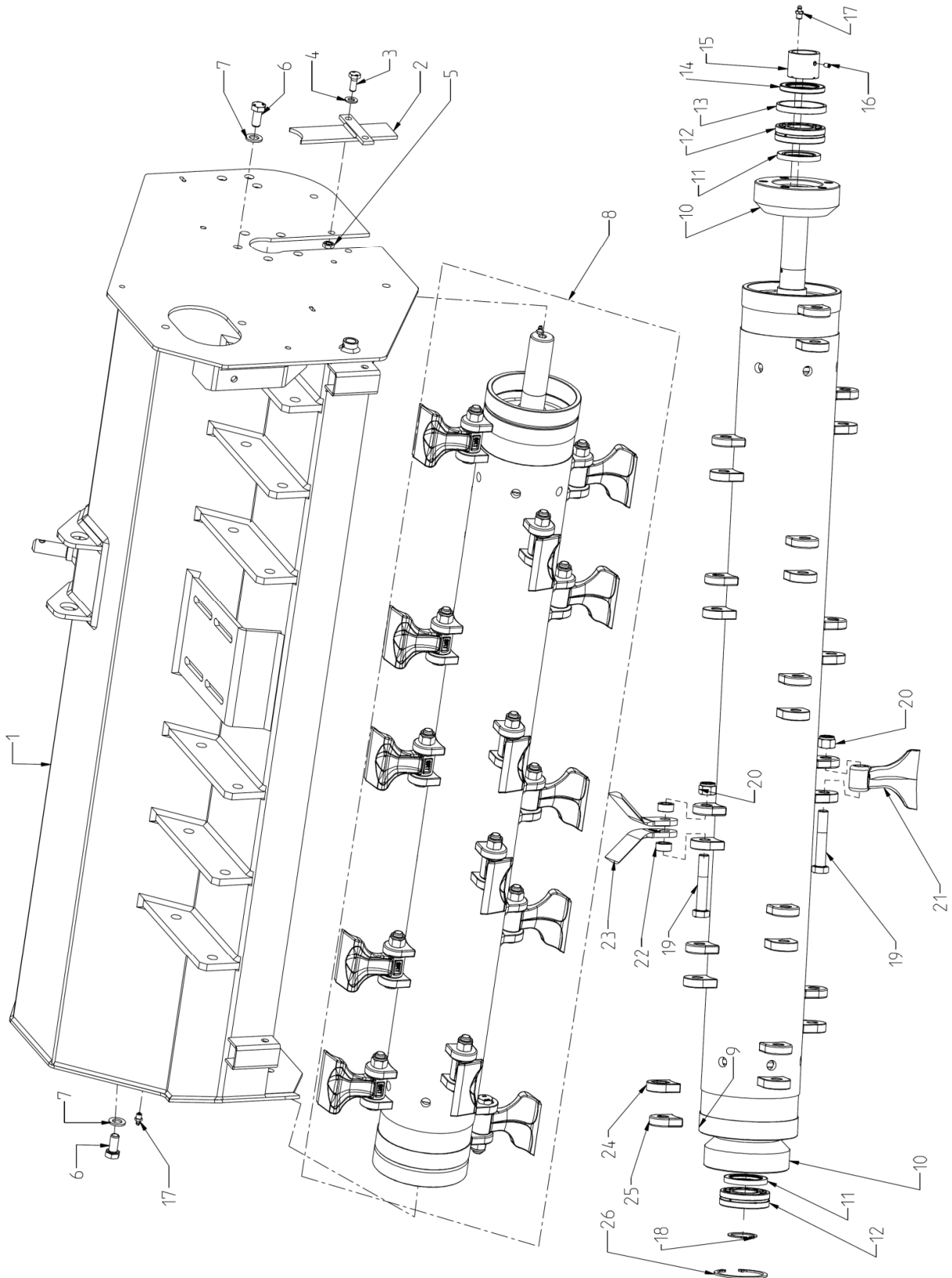

SHREDDER - SFM Series

MAIN FRAME & ROTOR ASSEMBLY PARTS			
Sr No.	Part no	Description	Qty.
1	17137	FRAME WELDMENT, FLAIL MOWER 145 (SFM)	1
	17138	FRAME WELDMENT, FLAIL MOWER 160 (SFM)	1
	17139	FRAME WELDMENT, FLAIL MOWER 175 (SFM)	1
	17140	FRAME WELDMENT, FLAIL MOWER 205 (SFM)	1
	17141	FRAME WELDMENT, FLAIL MOWER 220 (SFM)	1
	17334	FRAME WELDMENT, FLAIL MOWER 130 (SFM)	1
	17335	FRAME WELDMENT, FLAIL MOWER 115 (SFM)	1
	17336	FRAME WELDMENT, FLAIL MOWER 100 (SFM)	1
	17384	FRAME WELDMENT, FLAIL MOWER - 85 (SFM)	1
2	17142	CLOSING PLATE, WELDMENT (SFM)	1
3	17270	HEX BOLT M10 X 1.50 X 25 (8.8) DIN931	2
4	8078	PLAIN WASHER 10mm	2
5	17272	HEX NUT M10 X 1.50 DIN 934	2
6	17280	HEX BOLT M14 X 2 X 30 (8.8) DIN933	10
7	1272	PLAIN WASHER 14mm	10
8	17402	ROTOR ASSEMBLY 0.85M (Y- BLADE)(SFM)	1
	17401	ROTOR ASSEMBLY 1.00M (Y- BLADE)(SFM)	1
	17400	ROTOR ASSEMBLY 1.15M (Y- BLADE)(SFM)	1
	17399	ROTOR ASSEMBLY 1.30M (Y- BLADE)(SFM)	1
	17247	ROTOR ASSEMBLY 1.45M (Y-BLADE) (SFM)	1
	17248	ROTOR ASSEMBLY 1.60M (Y-BLADE) (SFM)	1
	17249	ROTOR ASSEMBLY 1.75M (Y-BLADE) (SFM)	1
	17250	ROTOR ASSEMBLY 2.05M (Y-BLADE) (SFM)	1
	17251	ROTOR ASSEMBLY 2.20M (Y-BLADE) (SFM)	1
	17386	ROTOR ASSEMBLY 0.85M (HAMMER BLADE)(SFM)	1
	17342	ROTOR ASSEMBLY 1.00M (HAMMER BLADE)(SFM)	1
	17341	ROTOR ASSEMBLY 1.15M (HAMMER BLADE)(SFM)	1
	17340	ROTOR ASSEMBLY 1.30M (HAMMER BLADE)(SFM)	1
	17252	ROTOR ASSEMBLY 1.45M (HAMMER BLADE)(SFM)	1
	17253	ROTOR ASSEMBLY 1.60M (HAMMER BLADE)(SFM)	1
	17254	ROTOR ASSEMBLY 1.75M (HAMMER BLADE)(SFM)	1
17255	ROTOR ASSEMBLY 2.05M (HAMMER BLADE)(SFM)	1	
17256	ROTOR ASSEMBLY 2.20M (HAMMER BLADE)(SFM)	1	
9	17385	ROTOR WELDMENT WITH EXTENSION, 85 (SFM)	1
	17339	ROTOR WELDMENT WITH EXTENSION, 100 (SFM)	1
	17338	ROTOR WELDMENT WITH EXTENSION, 115 (SFM)	1
	17337	ROTOR WELDMENT WITH EXTENSION, 130 (SFM)	1
	17144	ROTOR WELDMENT WITH EXTENSION, 145 (SFM)	1
	17145	ROTOR WELDMENT WITH EXTENSION, 160 (SFM)	1
	17146	ROTOR WELDMENT WITH EXTENSION, 175 (SFM)	1
	17147	ROTOR WELDMENT WITH EXTENSION, 205 (SFM)	1
	17148	ROTOR WELDMENT WITH EXTENSION, 220 (SFM)	1
10	17149	ROTOR HUB, TRANSMISSION SIDE (SFM)	2
11	17150	OIL SEAL 47 X 70 X 8	2
12	17151	BEARING 22208 (SKF)	2
13	17152	RING, ROTARY SEAL	1
14	17153	OIL SEAL 50 X 72 X 8	1
15	17154	SPACER, DRIVEN PULLEY (SFM)	1
16	12090	GRUB SCREW M6 X 1 X 10	1
17	20272	GREASE NIPPLE M10 X 1.50(STRAIGHT)	2
18	8027	EXTERNAL CIRCLIP 40MM	1
19	17279	HEX BOLT M16 X 2 X 90 (10.9)(SFM-085)	10
		HEX BOLT M16 X 2 X 90 (10.9)(SFM-100)	12
		HEX BOLT M16 X 2 X 90 (10.9)(SFM-115)	14
		HEX BOLT M16 X 2 X 90 (10.9)(SFM-130)	16
		HEX BOLT M16 X 2 X 90 (10.9)(SFM-145)	18
		HEX BOLT M16 X 2 X 90 (10.9)(SFM-160)	20
		HEX BOLT M16 X 2 X 90 (10.9)(SFM-175)	22
		HEX BOLT M16 X 2 X 90 (10.9)(SFM-205)	26
		HEX BOLT M16 X 2 X 90 (10.9)(SFM-220)	28

MAIN FRAME & ROTOR ASSEMBLY PARTS

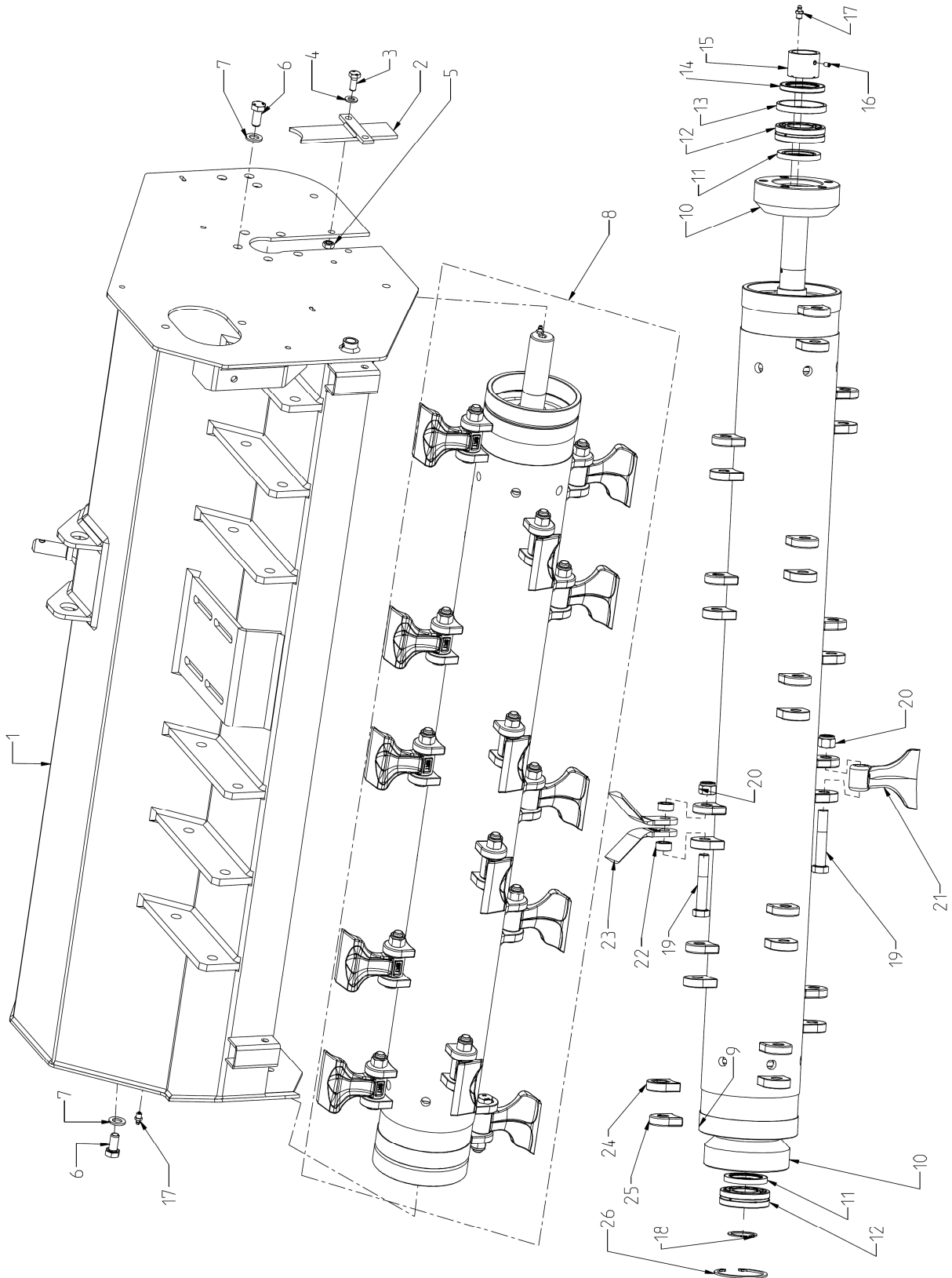

MAIN FRAME & ROTOR ASSEMBLY PARTS			
Sr No.	Part no	Description	Qty.
20	1231	M16X2 NYLOCK NUT(SFM-085)	10
		M16X2 NYLOCK NUT(SFM-100)	12
		M16X2 NYLOCK NUT(SFM-115)	14
		M16X2 NYLOCK NUT(SFM-130)	16
		M16X2 NYLOCK NUT(SFM-145)	18
		M16X2 NYLOCK NUT(SFM-166)	20
		M16X2 NYLOCK NUT(SFM-175)	22
		M16X2 NYLOCK NUT(SFM-205)	26
		M16X2 NYLOCK NUT(SFM-220)	28
21	17398	SET OF HAMMER BLADE(0.860), 0.85M (SFM)	1
	17383	SET OF HAMMER BLADE(0.860), 1.00M (SFM)	1
	17382	SET OF HAMMER BLADE(0.860), 1.15M (SFM)	1
	17381	SET OF HAMMER BLADE(0.860), 1.30M (SFM)	1
	17309	SET OF HAMMER BLADE(0.860), 1.45M (SFM)	1
	17310	SET OF HAMMER BLADE(0.860), 1.60M (SFM)	1
	17311	SET OF HAMMER BLADE(0.860), 1.75M (SFM)	1
	17312	SET OF HAMMER BLADE(0.860), 2.05M (SFM)	1
	17313	SET OF HAMMER BLADE(0.860), 2.20M (SFM)	1
22	17229	BLADE SPACER (SFM-085)	20
		BLADE SPACER (SFM-100)	24
		BLADE SPACER (SFM-115)	28
		BLADE SPACER (SFM130)	32
		BLADE SPACER (SFM-145)	36
		BLADE SPACER (SFM-160)	40
		BLADE SPACER (SFM-175)	44
		BLADE SPACER (SFM-205)	52
		BLADE SPACER (SFM-220)	56
23	17409	SET OF Y BLADE FOR 0.85M (SFM)	1
	17408	SET OF Y BLADE FOR 1.00M (SFM)	1
	17407	SET OF Y BLADE FOR 1.15M (SFM)	1
	17406	SET OF Y BLADE FOR 1.30M (SFM)	1
	17412	SET OF Y BLADE FOR 1.45M (SFM)	1
	17413	SET OF Y BLADE FOR 1.60M (SFM)	1
	17414	SET OF Y BLADE FOR 1.75M (SFM)	1
	17415	SET OF Y BLADE FOR 2.05M (SFM)	1
	17416	SET OF Y BLADE FOR 2.20M (SFM)	1
24	17410	HEX HOLDER (SFM-085)	10
		HEX HOLDER (SFM-100)	12
		HEX HOLDER (SFM-115)	14
		HEX HOLDER (SFM-130)	16
		HEX HOLDER (SFM145)	18
		HEX HOLDER (SFM-160)	20
		HEX HOLDER (SFM-175)	22
		HEX HOLDER (SFM-205)	26
		HEX HOLDER (SFM-220)	28
25	17411	ROUND HOLDER (SFM-085)	10
		ROUND HOLDER (SFM-100)	12
		ROUND HOLDER (SFM-115)	14
		ROUND HOLDER (SFM-130)	16
		ROUND HOLDER (SFM-145)	18
		ROUND HOLDER (SFM-160)	20
		ROUND HOLDER (SFM-175)	22
		ROUND HOLDER (SFM-205)	26
		ROUND HOLDER (SFM-220)	28
26	1130	CIRCLIP INTERNAL 80MM	1

TRANSMISSION & SKID PARTS

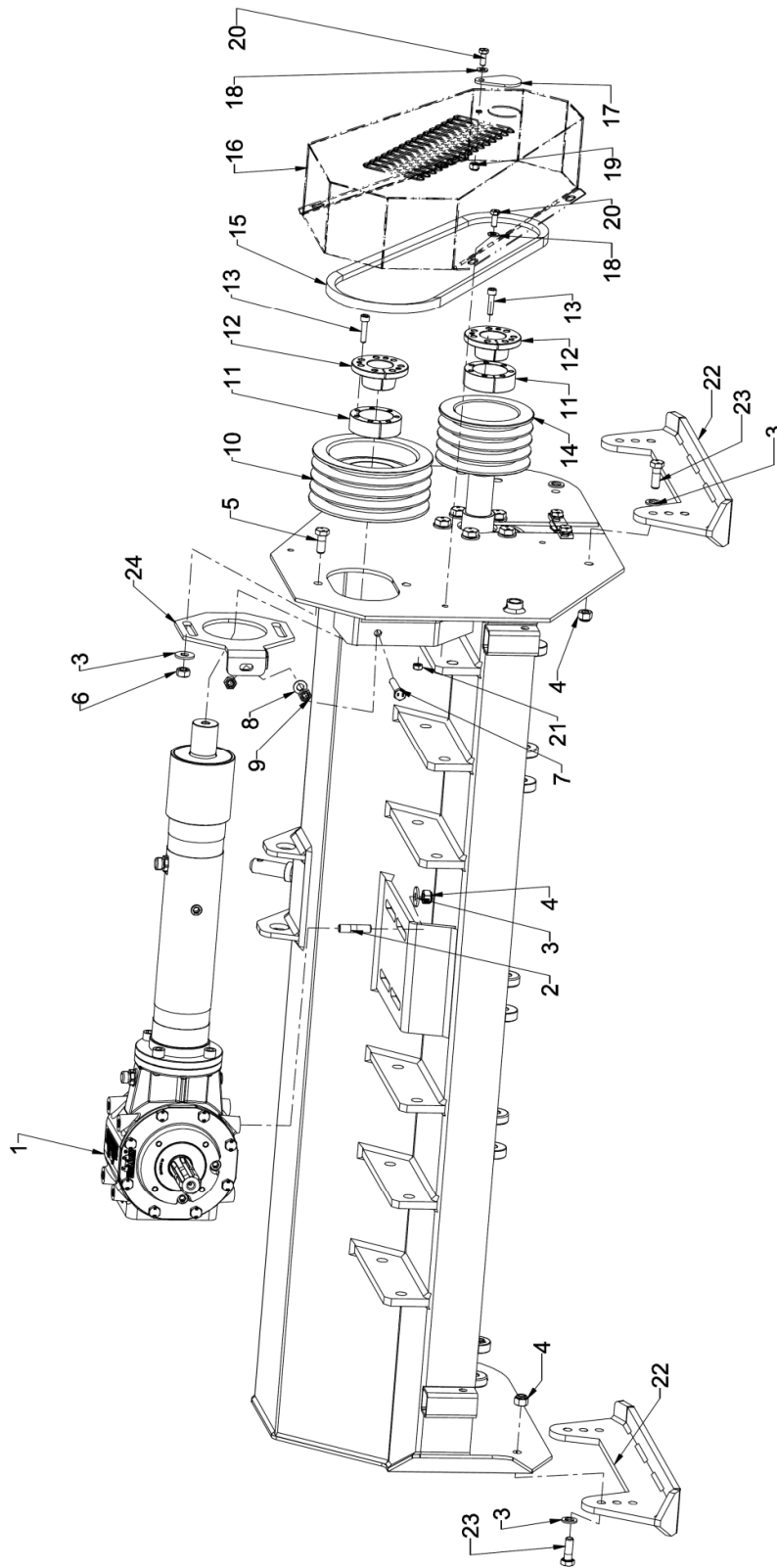

TRANSMISSION AND SKID PARTS			
Sr No.	Counter	Description	Qty.
1	17367	GEAR BOX ASS. (770MM) 540 RPM (SFM-220)-NEW	1
	17368	GEAR BOX ASS. (695MM) 540 RPM (SFM-205)-NEW	1
	17369	GEAR BOX ASS. (545MM) 540 RPM (SFM-175)-NEW	1
	17370	GEAR BOX ASS. (470MM) 540 RPM (SFM-160)-NEW	1
	17371	GEAR BOX ASS. (445MM) 540 RPM (SFM-145)-NEW	1
	17372	GEAR BOX ASS. (495MM) 540 RPM (SFM-130)-NEW	1
	17373	GEAR BOX ASS. (420MM) 540 RPM (SFM-115)-NEW	1
	17374	GEAR BOX ASS. (345MM) 540 RPM (SFM-100)-NEW	1
	17395	GEAR BOX ASS. (270MM) 540 RPM (SFM-085)-NEW	1
2	7018	STUD M12 X 1.75 X 50	4
3	17269	PLAIN WASHER 30 X 12 X 3	6
4	1209	M12X1.75 NYLOCK NUT	8
5	17275	HEX BOLT M12 X 1.75 X 30 (8.8) DIN931	2
6	17273	HEX NUT M12 X 1.75 DIN 934	2
7	17281	HEX BOLT M10 X 1.50 X 60(FT)(8.8) DIN933	1
8	8078	PLAIN WASHER 10mm	1
9	17272	HEX NUT M10 X 1.50 DIN 934	2
10	17161	SPB TYPE PULLEY-PITCH DIA 180, 4 GROOVES	1
	17405	SPB TYPE PULLEY-PITCH DIA 180, 3 GROOVES	1
11	17037	CLAMP OUTER (SRM)	2
12	17036	CLAMP INNER (SRM)	2
13	17035	ALLEN BOLT M8 X 1.25 X 35 (FT)(8.8)	14
14	17162	SPB TYPE PULLEY-PITCH DIA 140, 4 GROOVES	1
	17404	SPB TYPE PULLEY-PITCH DIA 140, 3 GROOVES	1
15	17698	SET OF V BELT BX47 (CONTITECH)(4 NOS)	3
	17699	SET OF V BELT BX47 (CONTITECH)(3 NOS)	4
16	17164	GUARD, BELT TRASMISSION (SFM)	1
	17403	GUARD, BELT TRASMISSION 3-GROOVE (SFM)	1
17	17165	PLATE, PROTECTION GREASE ZERK (SFM)	1
18	8040	HEX BOLT M8 X 1.25 X 20	5
19	8064	PLAIN WASHER 8mm	5
20	1297	M8X1.25 NYLOCK NUT	1
21	8181	HEX NUT M8 X 1.25	4
22	17166	SKID WELDMENT (SFM)	2
23	17274	HEX BOLT M12 X 1.75 X 35 (8.8) DIN931	4
24	17300	PLATE WELDMENT, BELT TENSIONING (SFM)	1

GEAR BOX ASSEMBLY PARTS

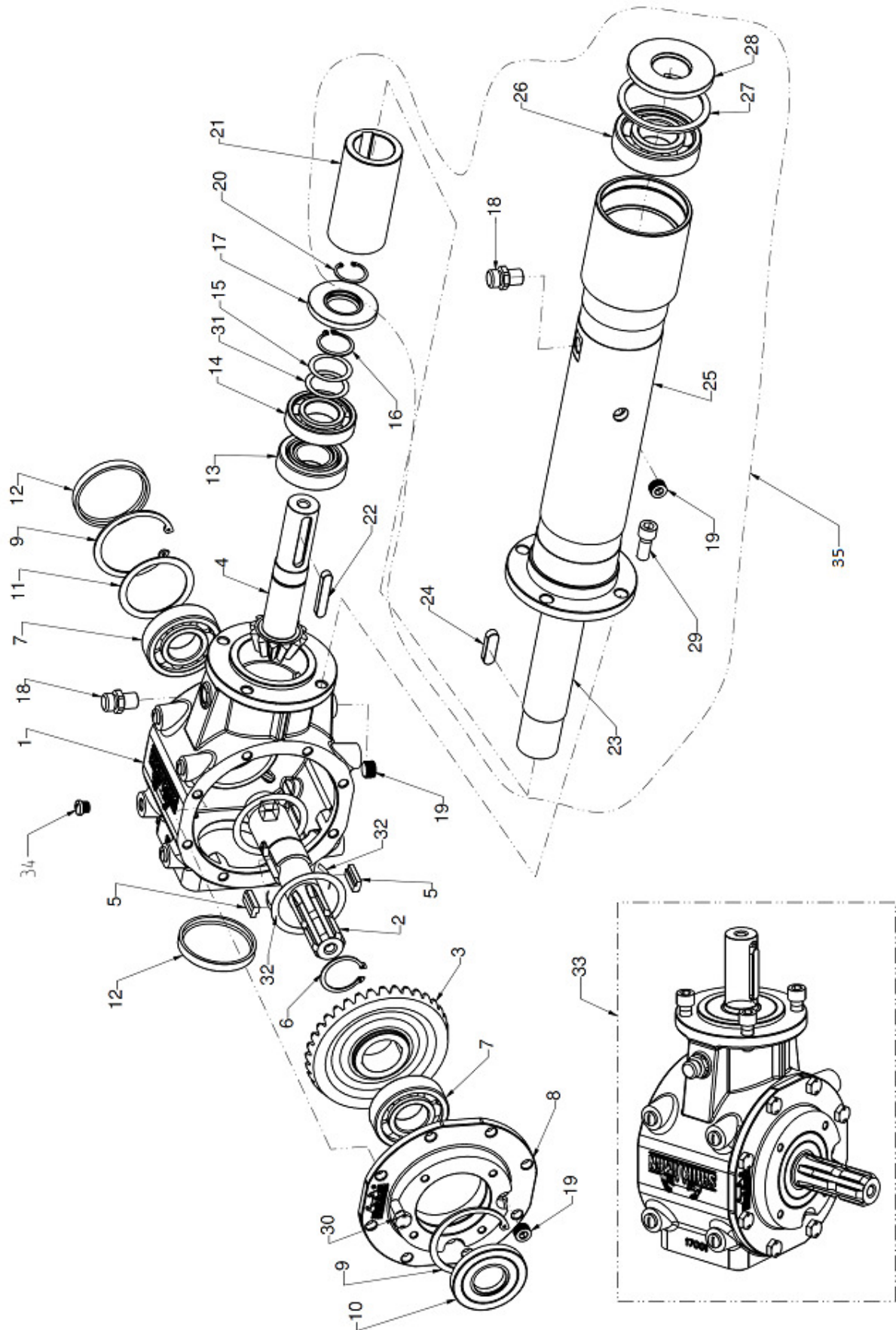

SHREDDER - SFM Series

GEAR BOX ASSEMBLY PARTS			
Sr No.	Counter	Description	Qty.
1	17001	GEAR BOX 540 RPM (SRM) 50HP	1
2	17244	INPUT SHAFT - FREE WHEEL	1
3	17577	CROWN 36 TEETH - FREE WHEEL (FORGED)	1
4	17576	PINION SHAFT 12 TEETH (FORGED)	1
5	17230	RATCHET 28MM	2
6	8027	CIRCLIP EXTERNAL 40MM	1
7	1131	BEARING 6307	2
8	17002	GEAR BOX FLANGE 540 RPM (SRM) 50HP	1
9	1130	INTERNAL CIRCLIP 6307(80MM)	2
10	17329	OIL SEAL 35 X 80 X 10 (NEW)	1
11	17167	SIMS (DIA 80 X 65)(0.5MM)	4
12	17633	OIL SEAL 80 X 10 (NEW)	2
13	17054	BEARING 32207B	1
14	10143	BEARING 6207	1
15	1424	SIMS (DIA 44.5 X 35.7)(0.50mm)	2
16	6024	EXTERNAL CIRCLIP 35MM	1
17	14309	OIL SEAL 35 X 72 X 8 (SPECIAL)	1
18	17258	CONICAL SPECIAL HEAD BOLT 3/8" BSP	2
19	14311	AIR BREATHER 3/8" BSP (1GTSSR210)	2
20	17083	CIRCLIP INTERNAL 32MM	1
21	17025	SHAFT CONNECTOR (SRM)	1
22	11077	PARALLEL KEY 10 X 8 X 56	1
23	17174	JACK SHAFT 770MM (SFM-220)	1
	17173	JACK SHAFT 695MM (SFM-205)	1
	17172	JACK SHAFT 545MM (SFM-175)	1
	17171	JACK SHAFT 470MM (SFM-160)	1
	17170	JACK SHAFT 445MM (SFM-145)	1
	17361	JACK SHAFT 485MM (SFM-130)	1
	17362	JACK SHAFT 410MM (SFM-115)	1
	17363	JACK SHAFT 335MM (SFM-100)	1
24	17393	JACK SHAFT 260MM (SFM-085)	1
24	11076	PARALLEL KEY 12 X 8 X 40	1
25	17324	JACK SHAFT HOUSING COMP 770MM (SFM-220)(NEW)	1
	17325	JACK SHAFT HOUSING COMP 695MM (SFM-205)(NEW)	1
	17326	JACK SHAFT HOUSING COMP 545MM (SFM-175)(NEW)	1
	17327	JACK SHAFT HOUSING COMP 470MM (SFM-160)(NEW)	1
	17328	JACK SHAFT HOUSING COMP 445MM (SFM145)(NEW)	1
	17364	JACK SHAFT HOUSING COMP 495MM (SFM-130)	1
	17365	JACK SHAFT HOUSING COMP 420MM (SFM-115)	1
	17366	JACK SHAFT HOUSING COMP 345MM (SFM-100)	1
26	17394	JACK SHAFT HOUSING COMP 270MM (SFM-085)	1
26	8036	BEARING 6308	1
27	3027	INTERNAL CIRCLIP 90MM	1
28	17026	OIL SEAL 90 X 40 X 8 (NEW)	1
29	17027	ALLEN BOLT M12 X 1.75 X 30 (FT)(8.8)	4
30	17270	HEX BOLT M10 X 1.50 X 25 (8.8) DIN931	8
31	1425	SIMS (DIA 45 X 35)(1.0MM)	1
32	17076	LEAF SPRING (SRM)	2
33	17677	GEAR BOX ASSEMBLY 50HP (SRM)	1
34	17675	PLASTIC CAP M12 X 1.75	8
35	17778	JACK SHAFT - HOUSING ASS 770MM (SFM-220)	1
	17779	JACK SHAFT - HOUSING ASS 695MM (SFM-205)	
	17780	JACK SHAFT - HOUSING ASS 545MM (SFM-175)	
	17781	JACK SHAFT - HOUSING ASS 470MM (SFM-160)	
	17782	JACK SHAFT - HOUSING ASS 445MM (SFM-145)	
	17783	JACK SHAFT - HOUSING ASS 485MM (SFM-130)	
	17784	JACK SHAFT - HOUSING ASS 410MM (SFM-115)	
	17785	JACK SHAFT - HOUSING ASS 335MM (SFM-100)	
17786	JACK SHAFT - HOUSING ASS 260MM (SFM-085)		

3 POINT MAST SIDE SHIFT ASSEMBLY - PARTS

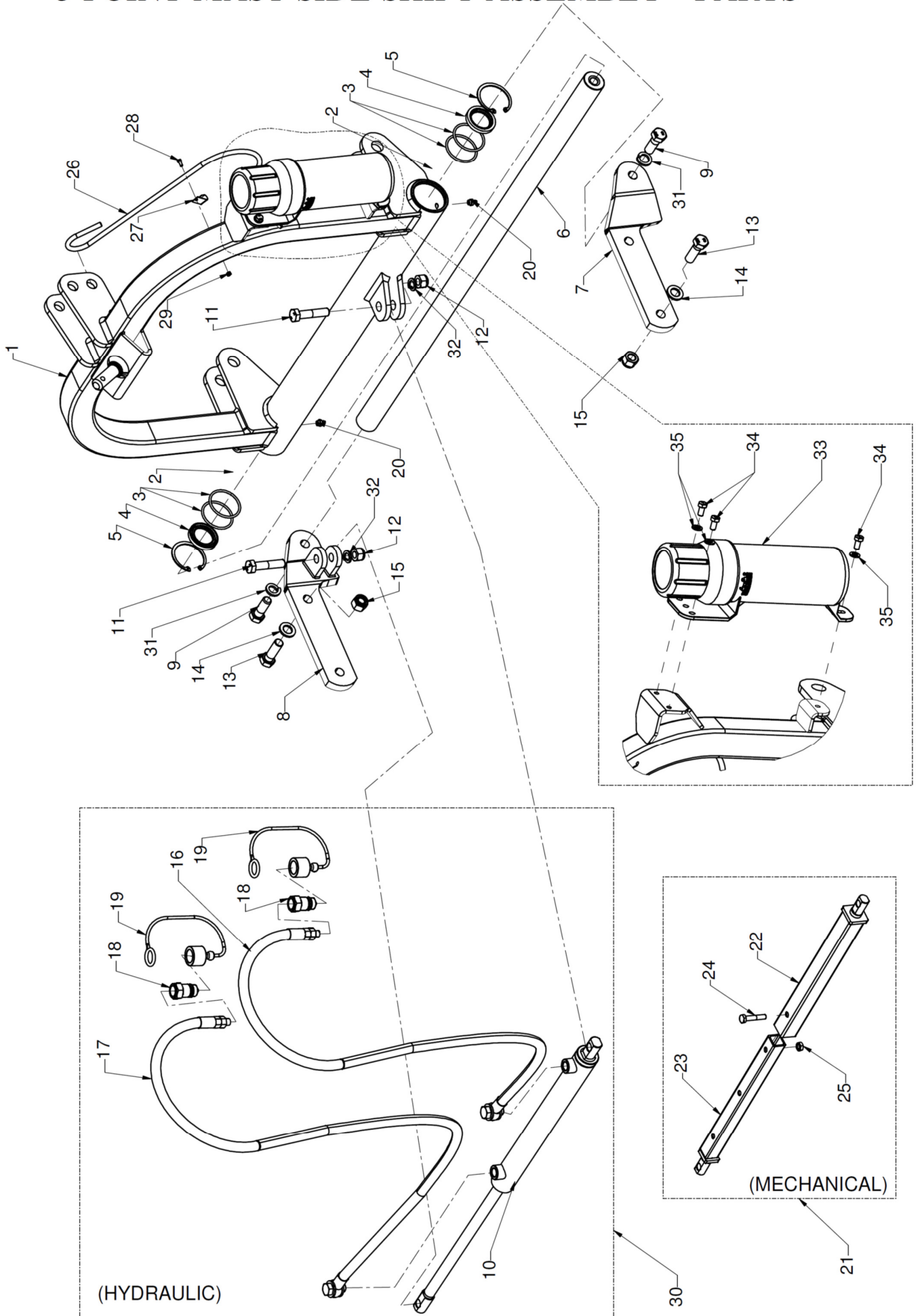

3 POINT MAST SIDE SHIFT ASSEMBLY- PARTS			
Sr No.	Counter	Description	Qty.
1	17180	MAST WELDMENT, HYDRAULIC (SFM)	1
2	17181	BUSHING (DI=40, DE=60, L=60) (SFM)	2
3	12127	O RING 52 X 3.5	4
4	17182	OIL SEAL 40 X 55 X 7	2
5	8120	CIRCLIP INTERNAL 62mm	2
6	17183	GUIDE BAR (L=1080MM) (SFM)	1
7	17184	BRACKET, LH (SFM)	1
8	17185	BRACKET WELDMENT (SFM)	1
9	17277	HEX BOLT M16 X 1.50 X 45 (8.8)	2
10	17578	HYDRAULIC JACK (STROKE-300) NEW	1
11	17417	HEX BOLT M14 X 1.50 X 65 (8.8) DIN931	2
12	1302	M14X1.5 NYLOCK NUT	2
13	17278	HEX BOLT M16 X 2 X 50 (8.8)	4
14	1078	PLAIN WASHER 16MM	4
15	1231	NYLOCK NUT M16 X 2	4
16	17188	HYDRAULIC PIPE COMP - 2000MM	1
17	17189	HYDRAULIC PIPE COMP - 2400MM	1
18	8290	QUICK COUPLING 1/2" MALE	2
19	18269	QRC PLASTIC CAP (1/2 BSP) FEMALE	2
20	20148	GREASE NIPPLE M8 X 1.25	2
21	17266	MANUAL JACK ASSEMBLY (SFM)	1
22	17264	OUTER PIPE MANUAL JACK COMP (SFM)	1
23	17265	INNER PIPE MANUAL JACK COMP (SFM)	1
24	17301	HEX BOLT M10 X 1.50 X 55(8.8) DIN 931	1
25	17272	HEX NUT M10 X 1.50 DIN 934	1
26	14341	DRIVELINE HOOK 320MM	1
27	23147	PLATE,HOOK HOLDING (JUMBO)	1
28	23029	HEX BOLT M4 X 0.75 X 10	1
29	23028	HEX NUT M4 X 0.75	1
30	17268	HYDRAULIC PARTS ASSEMBLY (SFM)	1
31	1308	SPRING WASHER 16mm	2
32	1307	SPRING WASHER 14mm	2
33	26030	MANUAL BOX COVER 1/2(SMMSD)	1
34	8064	PLAIN WASHER 8mm	3
35	8190	HEX BOLT M8 X 1.25 X 15	3

3 POINT MAST ASSEMBLY (SIDE SHIFT & FIX TYPE)

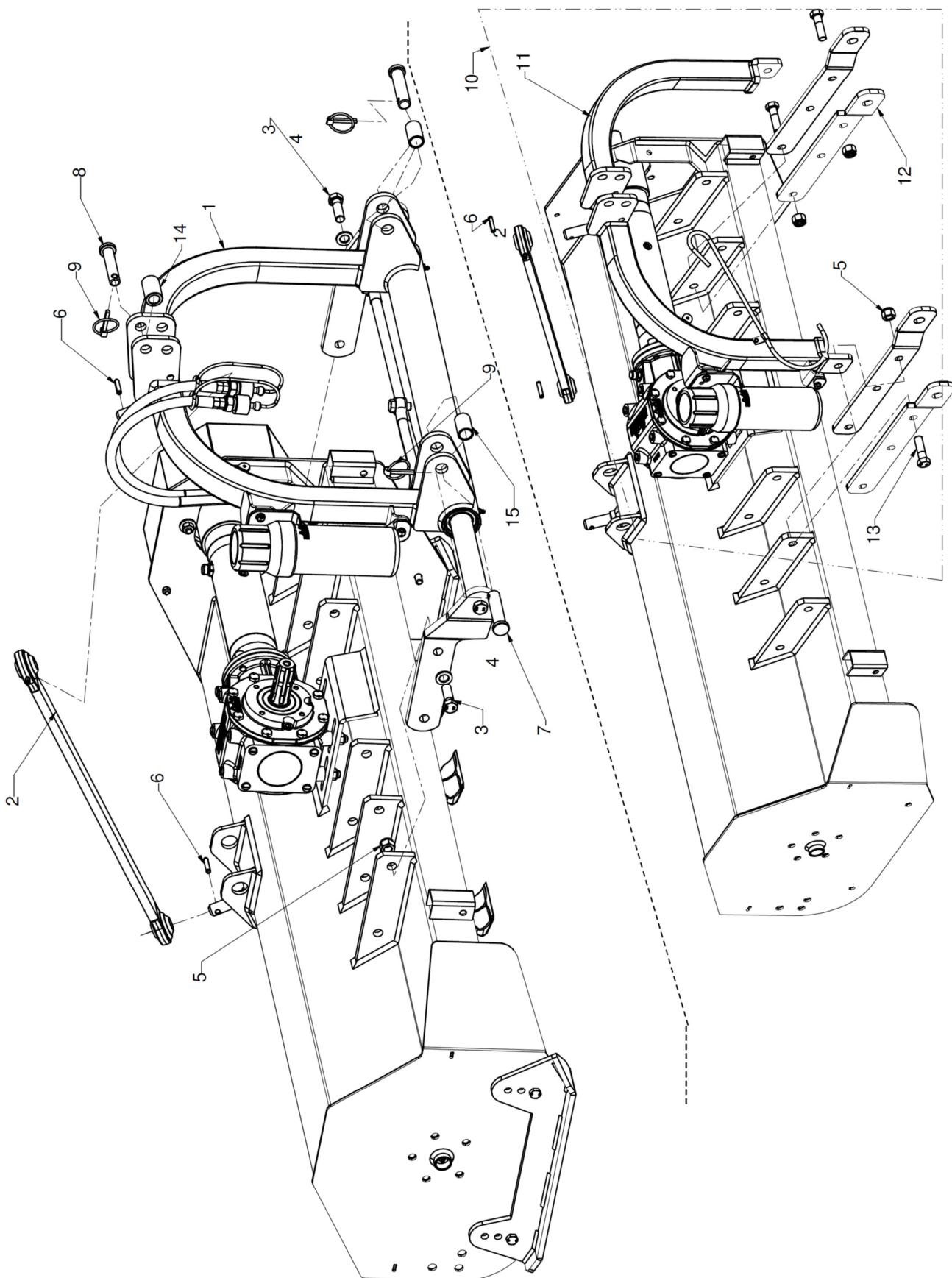

3 POINT MAST ASSEMBLY (SIDE SHIFT & FIX TYPE)			
Sr No.	Counter	Description	Qty.
1	17233	3 POINT MAST ASSEMBLY- HYDRAULIC (SFM)	1
2	17190	TIE-ROD WITH BALL-JOINTS (SFM)	1
3	17278	HEX BOLT M16 X 2 X 50 (8.8)	4
4	1078	PLAIN WASHER 16mm	4
5	1231	M16X2 NYLOCK NUT (FOR FIX)	4
		M16X2 NYLOCK NUT (FOR MOVABLE)	6
6	17191	DOWEL PIN DIA 8 X 36	2
7	15069	LOWER LINK PIN BUSH (SFB)	2
8	14086	BUSH (DIA. 19.4 X 25.4 X 52 L)	1
9	1218	LINCH PIN	3
10	17260	3 POINT MAST ASSEMBLY-FIX TYPE (SFM)	1
11	17234	MAST WELDMENT, FIXED TYPE (SFM)	1
12	17235	BRACKET-LOWER 3RD POINT ATTACHMENT (SFM)	4
13	18446	HEX BOLT M16 X 2 X 55 (8.8)	6

SHIELD, FRONT PLATES, PARKING STAND

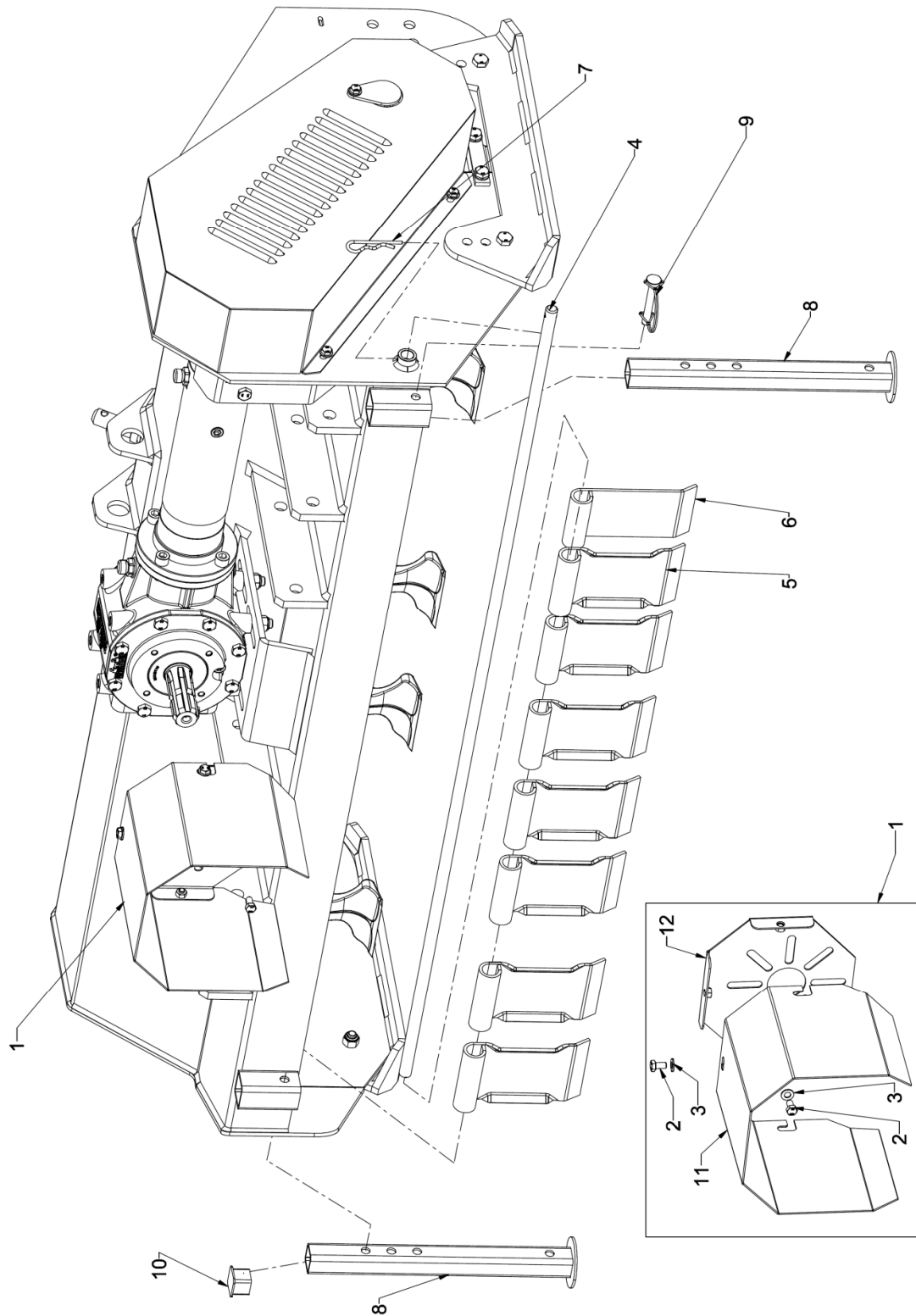

SHREDDER - SFM Series

SHIELD, FRONT PLATES, PARKING STAND			
Sr No.	Counter	Description	Qty.
1	17968	PTO SHAFT GUARD ASS SMALL (BMF)	1
2	8190	HEX BOLT M8 X 1.25 X 15	7
3	8064	PLAIN WASHER 8mm	7
4	17387	ROD, FRONT PLATES, 85 (SFM)	1
	17360	ROD, FRONT PLATES, 100 (SFM)	1
	17359	ROD, FRONT PLATES, 115 (SFM)	1
	17358	ROD, FRONT PLATES, 130 (SFM)	1
	17192	ROD, FRONT PLATES, 145 (SFM)	1
	17193	ROD, FRONT PLATES, 160 (SFM)	1
	17194	ROD, FRONT PLATES, 175 (SFM)	1
	17195	ROD, FRONT PLATES, 205 (SFM)	1
	17196	ROD, FRONT PLATES, 220 (SFM)	1
5	17197	FRONT PLATE, L=100 (SFM)(SFM-085)	8
		FRONT PLATE, L=100 (SFM)(SFM-100)	8
		FRONT PLATE, L=100 (SFM)(SFM-115)	10
		FRONT PLATE, L=100 (SFM)(SFM-130)	11
		FRONT PLATE, L=100 (SFM)(SFM-145)	13
		FRONT PLATE, L=100 (SFM)(SFM-160)	14
		FRONT PLATE, L=100 (SFM)(SFM-175)	16
		FRONT PLATE, L=100 (SFM)(SFM-205)	19
		FRONT PLATE, L=100 (SFM)(SFM-220)	20
6	17198	FRONT PLATE, L=85 (SFM-085)	0
		FRONT PLATE, L=85 (SFM-100)	1
		FRONT PLATE, L=85 (SFM-115)	0
		FRONT PLATE, L=85 (SFM-130)	1
		FRONT PLATE, L=85 (SFM-145)	0
		FRONT PLATE, L=85 (SFM-160)	1
		FRONT PLATE, L=85 (SFM-175)	0
		FRONT PLATE, L=85 (SFM-205)	0
		FRONT PLATE, L=85 (SFM-220)	1
7	15055	R-CLIP WIRE DIA 4.00MM	1
8	14013	M/C STAND PIPE COMP (U-SERIES)(SFM-085)	1
		M/C STAND PIPE COMP (U-SERIES)(SFM-100)	2
		M/C STAND PIPE COMP (U-SERIES)(SFM-115)	2
		M/C STAND PIPE COMP (U-SERIES)(SFM-130)	2
		M/C STAND PIPE COMP (U-SERIES)(SFM-145)	2
		M/C STAND PIPE COMP (U-SERIES)(SFM-160)	2
		M/C STAND PIPE COMP (U-SERIES)(SFM-175)	2
		M/C STAND PIPE COMP (U-SERIES)(SFM-205)	2
		M/C STAND PIPE COMP (U-SERIES)(SFM-220)	2
9	14267	SQ. SNAPPER PIN D10 X L70(SFM-085)	1
		SQ. SNAPPER PIN D10 X L70(SFM-100)	2
		SQ. SNAPPER PIN D10 X L70(SFM-115)	2
		SQ. SNAPPER PIN D10 X L70(SFM-130)	2
		SQ. SNAPPER PIN D10 X L70(SFM-145)	2
		SQ. SNAPPER PIN D10 X L70(SFM-160)	2
		SQ. SNAPPER PIN D10 X L70(SFM-175)	2
		SQ. SNAPPER PIN D10 X L70(SFM-205)	2
		SQ. SNAPPER PIN D10 X L70(SFM-220)	2
10	14266	SQ. PIPE PLASTIC CAP 32MM(SFM-085)	1
		SQ. PIPE PLASTIC CAP 32MM(SFM-100)	2
		SQ. PIPE PLASTIC CAP 32MM(SFM-115)	2
		SQ. PIPE PLASTIC CAP 32MM(SFM-130)	2
		SQ. PIPE PLASTIC CAP 32MM(SFM-145)	2
		SQ. PIPE PLASTIC CAP 32MM(SFM-160)	2
		SQ. PIPE PLASTIC CAP 32MM(SFM-175)	2
		SQ. PIPE PLASTIC CAP 32MM(SFM-205)	2
		SQ. PIPE PLASTIC CAP 32MM(SFM-220)	2
11	17970	PTO SHAFT GUARD SMALL (BMF)	1
12	17969	PTO SHAFT GUARD MOUNT PLATE COMP (BMF)	1

KIT (REAR COVER STANDARD)

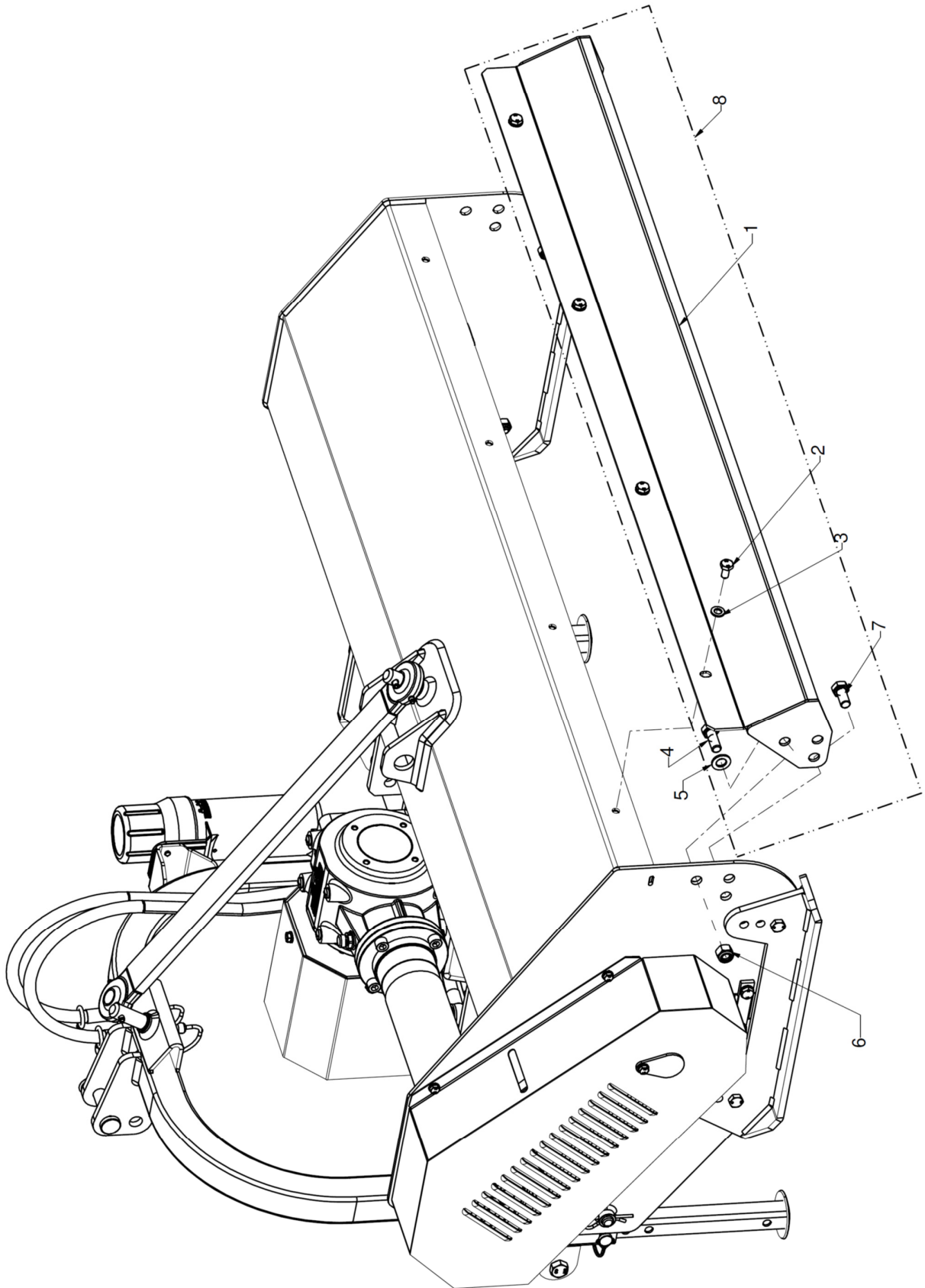

KIT - REAR COVER STANDARD			
Sr No.	Counter	Description	Qty.
1	17388	STANDARD REAR COVER WELDMENT, 85 (SFM)	1
	17345	STANDARD REAR COVER WELDMENT, 100 (SFM)	1
	17344	STANDARD REAR COVER WELDMENT, 115 (SFM)	1
	17343	STANDARD REAR COVER WELDMENT, 130 (SFM)	1
	17199	STANDARD REAR COVER WELDMENT, 145 (SFM)	1
	17200	STANDARD REAR COVER WELDMENT, 160 (SFM)	1
	17201	STANDARD REAR COVER WELDMENT, 175 (SFM)	1
	17202	STANDARD REAR COVER WELDMENT, 205 (SFM)	1
	17203	STANDARD REAR COVER WELDMENT, 220 (SFM)	1
2	17276	HEX BOLT M10 X 1.50 X 20(FT)(8.8) DIN933(SFM-085)	3
		HEX BOLT M10 X 1.50 X 20(FT)(8.8) DIN933(SFM-100)	
		HEX BOLT M10 X 1.50 X 20(FT)(8.8) DIN933(SFM-115)	
		HEX BOLT M10 X 1.50 X 20(FT)(8.8) DIN934(SFM-130)	4
		HEX BOLT M10 X 1.50 X 20(FT)(8.8) DIN935(SFM-145)	
		HEX BOLT M10 X 1.50 X 20(FT)(8.8) DIN936(SFM-160)	
		HEX BOLT M10 X 1.50 X 20(FT)(8.8) DIN937(SFM-175)	
		HEX BOLT M10 X 1.50 X 20(FT)(8.8) DIN938(SFM-205)	5
HEX BOLT M10 X 1.50 X 20(FT)(8.8) DIN939(SFM-220)			
3	8078	PLAIN WASHER 10mm(SFM-085)	3
		PLAIN WASHER 10mm(SFM-100)	
		PLAIN WASHER 10mm(SFM-115)	
		PLAIN WASHER 10mm(SFM-130)	4
		PLAIN WASHER 10mm(SFM-145)	
		PLAIN WASHER 10mm(SFM-160)	
		PLAIN WASHER 10mm(SFM-175)	
		PLAIN WASHER 10mm(SFM-205)	5
PLAIN WASHER 10mm(SFM-220)			
4	23318	HEX BOLT M14 X 1.50 X 40 (8.8) DIN931	4
5	1272	PLAIN WASHER 14mm	6
6	1302	M14X1.5 NYLOCK NUT	6
7	17282	HEX BOLT M14 X 1.50 X 30 (8.8) DIN933	2
8	17397	STANDARD REAR COVER ASSEMBLY, 85 (SFM)	1
	17380	STANDARD REAR COVER ASSEMBLY, 100(SFM)	1
	17379	STANDARD REAR COVER ASSEMBLY, 115(SFM)	1
	17378	STANDARD REAR COVER ASSEMBLY, 130(SFM)	1
	17319	STANDARD REAR COVER ASSEMBLY, 145 (SFM)	1
	17320	STANDARD REAR COVER ASSEMBLY, 160 (SFM)	1
	17321	STANDARD REAR COVER ASSEMBLY, 175 (SFM)	1
	17322	STANDARD REAR COVER ASSEMBLY, 205 (SFM)	1
	17323	STANDARD REAR COVER ASSEMBLY, 220 (SFM)	1

KIT (REAR ROLLER)

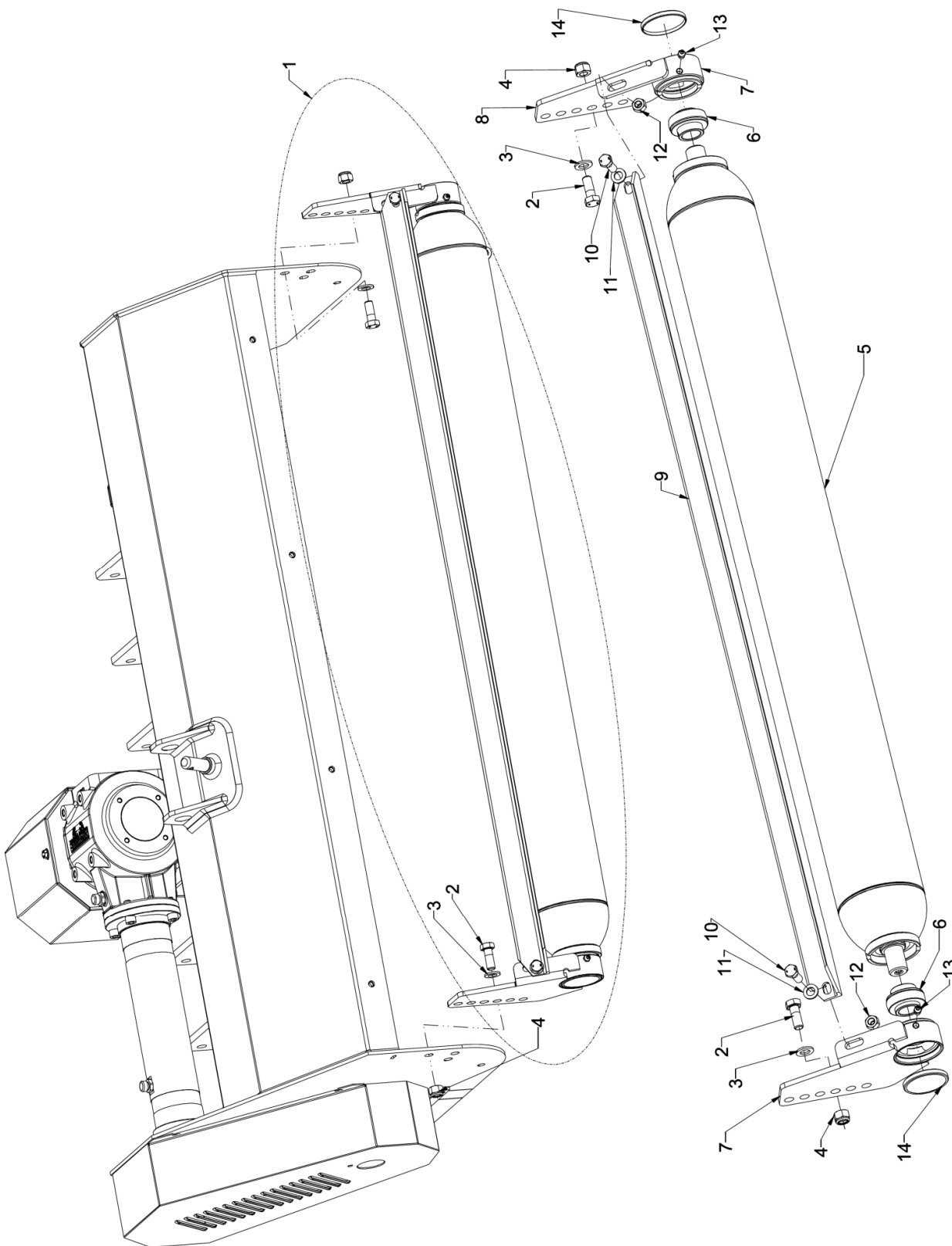

KIT- REAR ROLLER			
SR NO.	PART CODE	PART DESCRIPTION	QTY.
1	17392	REAR ROLLER ASSEMBLY, 85 (SFM)	1
	17357	REAR ROLLER ASSEMBLY 100 (SFM)	1
	17356	REAR ROLLER ASSEMBLY 115 (SFM)	1
	17355	REAR ROLLER ASSEMBLY 130 (SFM)	1
	17204	REAR ROLLER ASSEMBLY 145 (SFM)	1
	17205	REAR ROLLER ASSEMBLY 160 (SFM)	1
	17206	REAR ROLLER ASSEMBLY 175 (SFM)	1
	17207	REAR ROLLER ASSEMBLY 205 (SFM)	1
	17208	REAR ROLLER ASSEMBLY 220 (SFM)	1
2	23318	HEX BOLT M14 X 1.50 X 40 (8.8) DIN931	4
3	1272	PLAIN WASHER 14mm	4
4	1302	M14X1.5 NYLOCK NUT	4
5	17213	REAR ROLLER WELDMENT, 220 (SFM)	1
	17212	REAR ROLLER WELDMENT, 205 (SFM)	1
	17211	REAR ROLLER WELDMENT, 175 (SFM)	1
	17210	REAR ROLLER WELDMENT, 160 (SFM)	1
	17209	REAR ROLLER WELDMENT, 145 (SFM)	1
	17352	REAR ROLLER WELDMENT, 130 (SFM)	1
	17353	REAR ROLLER WELDMENT, 115 (SFM)	1
	17354	REAR ROLLER WELDMENT, 100 (SFM)	1
	17391	REAR ROLLER WELDMENT, 85 (SFM)	1
6	17214	BEARING-UC 206MM	2
7	17215	ROLLER MOUNT WELDMENT, LH (SFM)	1
8	17216	ROLLER MOUNT WELDMENT, RH (SFM)	1
9	17390	SCRAPER, 85 (SFM)	1
	17351	SCRAPER, 100 (SFM)	1
	17350	SCRAPER, 115 (SFM)	1
	17349	SCRAPER, 130 (SFM)	1
	17217	SCRAPER, 145 (SFM)	1
	17218	SCRAPER, 160 (SFM)	1
	17219	SCRAPER, 175 (SFM)	1
	17220	SCRAPER, 205 (SFM)	1
	17221	SCRAPER, 220 (SFM)	1
10	17274	HEX BOLT M12 X 1.75 X 35 (8.8) DIN931	2
11	8126	PLAIN WASHER 12mm	2
12	1209	M12X1.75 NYLOCK NUT	2
13	20272	GREASE NIPPLE M10 X 1.50(STRAIGHT)	2
14	14119	OIL SEAL 72 x 8	2

KIT (REAR COVER WITH RACKS)

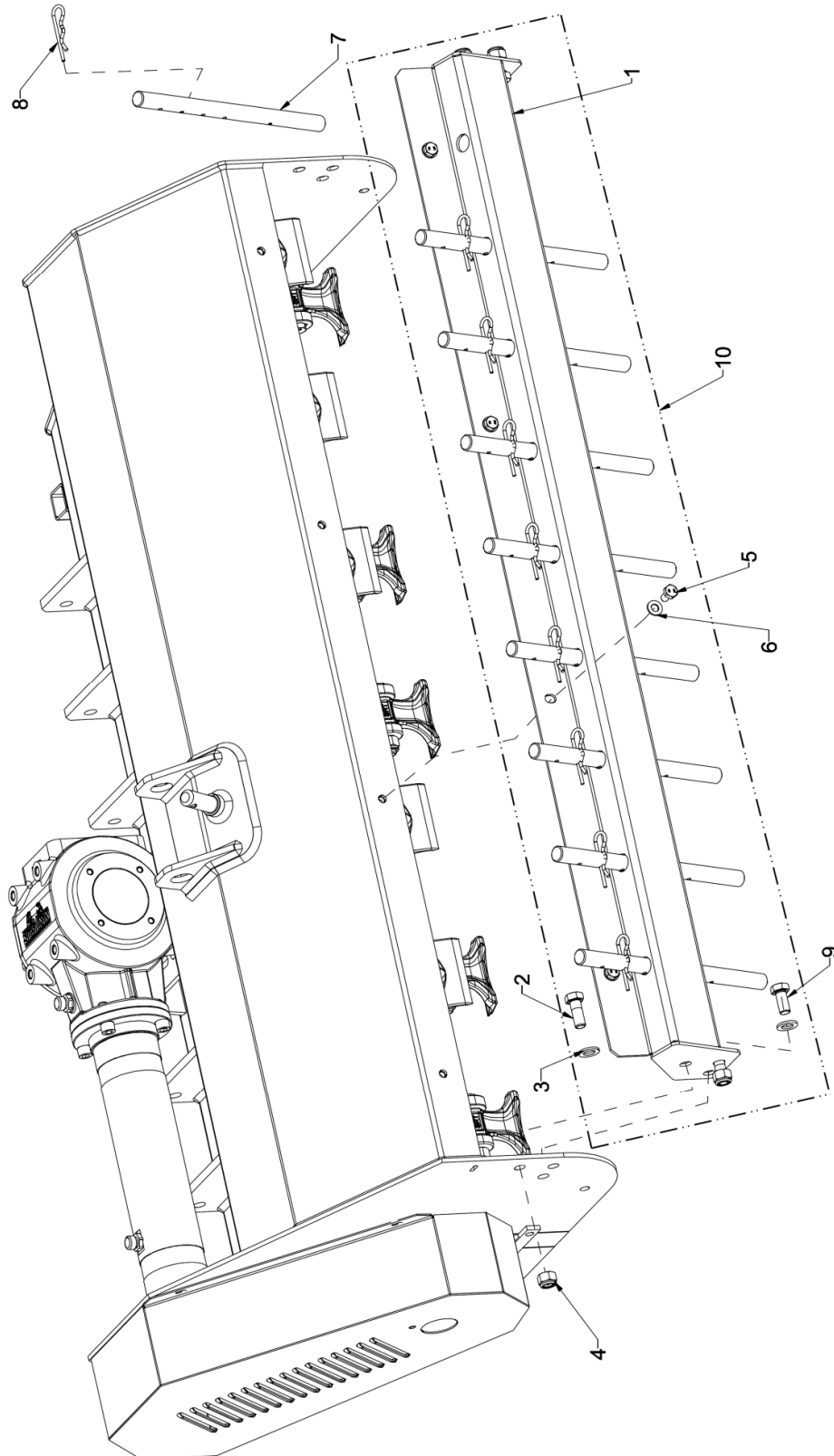

SHREDDER - SFM Series

KIT - REAR COVER WITH RACKS			
Sr No.	Counter	Description	Qty.
1	17389	RACKS REAR COVER, WELDMENT, 85 (SFM)	1
	17348	RACKS REAR COVER, WELDMENT, 100 (SFM)	1
	17347	RACKS REAR COVER, WELDMENT, 115 (SFM)	1
	17346	RACKS REAR COVER, WELDMENT, 130 (SFM)	1
	17222	RACKS REAR COVER, WELDMENT, 145 (SFM)	1
	17223	RACKS REAR COVER, WELDMENT, 160 (SFM)	1
	17224	RACKS REAR COVER, WELDMENT, 175 (SFM)	1
	17225	RACKS REAR COVER, WELDMENT, 205 (SFM)	1
	17226	RACKS REAR COVER, WELDMENT, 220 (SFM)	1
2	23318	HEX BOLT M14 X 1.50 X 40 (8.8) DIN931	4
3	1272	PLAIN WASHER 14mm	6
4	1302	M14X1.5 NYLOCK NUT	6
5	8010	HEX BOLT M10 X 1.50 X 20(SFM-085)	3
		HEX BOLT M10 X 1.50 X 20(SFM-100)	
		HEX BOLT M10 X 1.50 X 20(SFM-115)	
		HEX BOLT M10 X 1.50 X 20(SFM-130)	4
		HEX BOLT M10 X 1.50 X 20(SFM-145)	
		HEX BOLT M10 X 1.50 X 20(SFM-160)	
		HEX BOLT M10 X 1.50 X 20(SFM-175)	
		HEX BOLT M10 X 1.50 X 20(SFM-205)	5
		HEX BOLT M10 X 1.50 X 20(SFM-220)	
6	8078	PLAIN WASHER 10mm(SFM-085)	3
		PLAIN WASHER 10mm(SFM-100)	
		PLAIN WASHER 10mm(SFM-115)	
		PLAIN WASHER 10mm(SFM-130)	4
		PLAIN WASHER 10mm(SFM-145)	
		PLAIN WASHER 10mm(SFM-160)	
		PLAIN WASHER 10mm(SFM-175)	
		PLAIN WASHER 10mm(SFM-205)	5
		PLAIN WASHER 10mm(SFM-220)	
7	17227	RACK D22 L350 (SFM-085)	5
		RACK D22 L350 (SFM-100)	6
		RACK D22 L350 (SFM-115)	7
		RACK D22 L350 (SFM-130)	8
		RACK D22 L350 (SFM-145)	9
		RACK D22 L350 (SFM-160)	10
		RACK D22 L350 (SFM-175)	11
		RACK D22 L350 (SFM-205)	13
		RACK D22 L350 (SFM-220)	14
8	15055	R-CLIP WIRE DIA 4.00MM(SFM-085)	5
		R-CLIP WIRE DIA 4.00MM(SFM-100)	6
		R-CLIP WIRE DIA 4.00MM(SFM-115)	7
		R-CLIP WIRE DIA 4.00MM(SFM-130)	8
		R-CLIP WIRE DIA 4.00MM(SFM-145)	9
		R-CLIP WIRE DIA 4.00MM(SFM-160)	10
		R-CLIP WIRE DIA 4.00MM(SFM-175)	11
		R-CLIP WIRE DIA 4.00MM(SFM-205)	13
		R-CLIP WIRE DIA 4.00MM(SFM-220)	14
9	17282	HEX BOLT M14 X 1.50 X 30 (8.8) DIN933	2
10	17396	REAR COVER WITH RACKS ASS., 85 (SFM)	1
	17377	REAR COVER WITH RACKS ASS., 100 (SFM)	1
	17376	REAR COVER WITH RACKS ASS., 115 (SFM)	1
	17375	REAR COVER WITH RACKS ASS., 130 (SFM)	1
	17304	REAR COVER WITH RACKS ASS., 145 (SFM)	1
	17305	REAR COVER WITH RACKS ASS., 160 (SFM)	1
	17306	REAR COVER WITH RACKS ASS., 175 (SFM)	1
	17307	REAR COVER WITH RACKS ASS., 205 (SFM)	1
	17308	REAR COVER WITH RACKS ASS., 220 (SFM)	1



Tirth Agro Technology Pvt. Ltd.

"SHAKTIMAN", Survey No.-108/1,
Plot No. B, NH-27, Nr. Bharudi Toll Plaza,
Bhunava (Village), Taluka: Gondal,
Dist.: Rajkot – 360311,
State: Gujarat- INDIA,
Phone: + 91 (2827) 661637 / 270537
Fax: + 91 (2827) 270457
e-mail: info@shaktimanagro.com
www.shaktimanagro.com

